



Agilent Technologies E9850A
Embedded VXI Controller
User and Service Manual



Agilent Technologies



Manual Part Number: E9850-90000
Printed in U.S.A. E0500

Contents

E9850A User and Service Manual

Edition 1

AGILENT TECHNOLOGIES WARRANTY STATEMENT.....	5
Safety Symbols	6
WARNINGS	6
Preface	9
Manual Organization	9
Conventions Used in This Manual	9
How to Use The Documentation Set	10
Using the Agilent Documentation Set	10
Using the National Instruments Documentation Set	11
Related Documentation.....	12
Customer Support	12
Chapter 1	
Introducing the E9850A	13
Chapter Overview	13
Hardware Features	13
Software Overview	14
Software Architecture	14
Driver Software	15
Applications Software	17
Chapter 2	
Installing the E9850A	19
Chapter Overview	19
Checking Your Shipment.....	19
Installing the E9850A	21
Using the BIOS Setup Program	24
Reloading the Hard Drive Image	24
Chapter 3	
Developing Your Application	25
Chapter Overview	25
Getting Started	25
See Latest Information Files	25
Using Configuration Utilities	25
Configuration.....	26
Resman and T&M Explorer Description	26
Using Resman	26
Using T&M Explorer	27
Device Interaction.....	27
Programming	27

Programming with SICL	27
Programming with VISA	28
VME Support	28
Debugging.....	29
Using NI Spy	29
Using VISAIC	29
Chapter 4	
E9850A Description	31
Chapter Overview	31
Front Panel Features	31
LED Indicators.....	33
Functional Description	34
Chapter 5	
E9850A Configuration	39
Chapter Overview	39
Hardware Default Settings.....	39
T&M Explorer Default Settings	41
Configuring the E9850A.....	42
System Controller Operation (J12)	43
Power-On Self-Configuration (S2)	43
MITE EEPROM Settings (S1)	44
SCSI Termination (W11, W12)	45
System CMOS (W6)	46
CPU Bus Speed (W4)	46
CPU Bus Factor (W1, W3, W5, W7)	47
Flash Protection (W8)	47
Ethernet Serial EEPROM (W10)	47
Voltage Monitor (W15)	48
CLK10 Routing and Termination (T&M Explorer)	48
Trigger Input Termination (T&M Explorer)	48
Using WatchDOG (T&M Explorer)	48
Chapter 6	
Servicing the E9850A	49
Chapter Overview	49
Replaceable Parts List.....	49
Exchanging the E9850A	50
Troubleshooting Techniques.....	51
Repair/Installation Guidelines	52
Cleaning Instructions	52
Changing Main Power Fuse	52
Removing the E9850A Cover	53
Adding Additional RAM	54
Replacing the Hard Drive	54
Installing I/O Expansion Cards	55

Appendix A	
E9850A Specifications	59
Appendix Overview	59
General VXI Specifications	59
Physical	59
Environmental	60
Current Requirements	60
VMEbus Capability Codes	61
Appendix B	
Frequently Asked Questions	63
Appendix C	
Customer Support	67
If You Have Questions	67
E9850A Configuration Form	68
Appendix D	
Porting Considerations	71
Introduction	71
Default SICL Interface Name Changes	71
Resource Manager Differences	71
A24/A32 Memory Allocation	71
VXI IRQ Line Allocation	72
PCI User Window	73
SICL/VISA Differences	73
Mixing SICL and VISA	73
SICL on NI-VXI	73
SICL on NI GPIB (NI-488.2)	75
Appendix E	
Connector Descriptions	77
Appendix Overview	77
SVGA Connector	78
Keyboard/Mouse Connectors	79
Universal Serial Bus (USB) Connector	80
Speaker Connection	81
COM1 and COM2 Connectors	82
Parallel Port Connector	83
SCSI Connector	85
Ethernet Connector	87
GPIB (IEEE 488.2) Connector	88
External SMB Connectors	90
Rear Panel (P1 and P2) Connectors	91
Glossary	93
Index	99

Notes:

AGILENT TECHNOLOGIES WARRANTY STATEMENT

AGILENT PRODUCT: E9850A Embedded VXI Controller

DURATION OF WARRANTY: 1 year

1. Agilent Technologies warrants Agilent hardware, accessories and supplies against defects in materials and workmanship for the period specified above. If Agilent receives notice of such defects during the warranty period, Agilent will, at its option, either repair or replace products which prove to be defective. Replacement products may be either new or like-new.

2. Agilent warrants that Agilent software will not fail to execute its programming instructions, for the period specified above, due to defects in material and workmanship when properly installed and used. If Agilent receives notice of such defects during the warranty period, Agilent will replace software media which does not execute its programming instructions due to such defects.

3. Agilent does not warrant that the operation of Agilent products will be interrupted or error free. If Agilent is unable, within a reasonable time, to repair or replace any product to a condition as warranted, customer will be entitled to a refund of the purchase price upon prompt return of the product.

4. Agilent products may contain remanufactured parts equivalent to new in performance or may have been subject to incidental use.

5. The warranty period begins on the date of delivery or on the date of installation if installed by Agilent. If customer schedules or delays Agilent installation more than 30 days after delivery, warranty begins on the 31st day from delivery.

6. Warranty does not apply to defects resulting from (a) improper or inadequate maintenance or calibration, (b) software, interfacing, parts or supplies not supplied by Agilent, (c) unauthorized modification or misuse, (d) operation outside of the published environmental specifications for the product, or (e) improper site preparation or maintenance.

7. TO THE EXTENT ALLOWED BY LOCAL LAW, THE ABOVE WARRANTIES ARE EXCLUSIVE AND NO OTHER WARRANTY OR CONDITION, WHETHER WRITTEN OR ORAL, IS EXPRESSED OR IMPLIED AND AGILENT SPECIFICALLY DISCLAIMS ANY IMPLIED WARRANTY OR CONDITIONS OF MERCHANTABILITY, SATISFACTORY QUALITY, AND FITNESS FOR A PARTICULAR PURPOSE.

8. Agilent will be liable for damage to tangible property per incident up to the greater of \$300,000 or the actual amount paid for the product that is the subject of the claim, and for damages for bodily injury or death, to the extent that all such damages are determined by a court of competent jurisdiction to have been directly caused by a defective Agilent product.

9. TO THE EXTENT ALLOWED BY LOCAL LAW, THE REMEDIES IN THIS WARRANTY STATEMENT ARE CUSTOMER'S SOLE AND EXCLUSIVE REMEDIES. EXCEPT AS INDICATED ABOVE, IN NO EVENT WILL AGILENT OR ITS SUPPLIERS BE LIABLE FOR LOSS OF DATA OR FOR DIRECT, SPECIAL, INCIDENTAL, CONSEQUENTIAL (INCLUDING LOST PROFIT OR DATA), OR OTHER DAMAGE, WHETHER BASED IN CONTRACT, TORT, OR OTHERWISE.

FOR CONSUMER TRANSACTIONS IN AUSTRALIA AND NEW ZEALAND: THE WARRANTY TERMS CONTAINED IN THIS STATEMENT, EXCEPT TO THE EXTENT LAWFULLY PERMITTED, DO NOT EXCLUDE, RESTRICT OR MODIFY AND ARE IN ADDITION TO THE MANDATORY STATUTORY RIGHTS APPLICABLE TO THE SALE OF THIS PRODUCT TO YOU.

U.S. Government Restricted Rights

The Software and Documentation have been developed entirely at private expense. They are delivered and licensed as "commercial computer software" as defined in DFARS 252.227- 7013 (Oct 1988), DFARS 252.211-7015 (May 1991) or DFARS 252.227-7014 (Jun 1995), as a "commercial item" as defined in FAR 2.101(a), or as "Restricted computer software" as defined in FAR 52.227-19 (Jun 1987)(or any equivalent agency regulation or contract clause), whichever is applicable. You have only those rights provided for such Software and Documentation by the applicable FAR or DFARS clause or the Agilent standard software agreement for the product involved.



Agilent Technologies

E9850A Embedded VXI Controller User and Service Manual
Edition 1

Copyright © 2000 Agilent Technologies, Inc. All rights reserved.
Copyright © 2000 National Instruments Corporation. All rights reserved.
Courtesy National Instruments Corporation, reproduced by permission.

Documentation History

All Editions and Updates of this manual and their creation date are listed below. The first Edition of the manual is Edition 1. The Edition number increments by 1 whenever the manual is revised. Updates, which are issued between Editions, contain replacement pages to correct or add additional information to the current Edition of the manual. Whenever a new Edition is created, it will contain all of the Update information for the previous Edition. Each new Edition or Update also includes a revised copy of this documentation history page.

Edition 1May, 2000

Safety Symbols



Instruction manual symbol affixed to product. Indicates that the user must refer to the manual for specific WARNING or CAUTION information to avoid personal injury or damage to the product.



Indicates the field wiring terminal that must be connected to earth ground before operating the equipment — protects against electrical shock in case of fault.

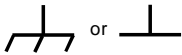

Frame or chassis ground terminal—typically connects to the equipment's metal frame.



Alternating current (AC)



Direct current (DC).



Indicates hazardous voltages.

WARNING

Calls attention to a procedure, practice, or condition that could cause bodily injury or death.

CAUTION

Calls attention to a procedure, practice, or condition that could possibly cause damage to equipment or permanent loss of data.

WARNINGS

The following general safety precautions must be observed during all phases of operation, service, and repair of this product. Failure to comply with these precautions or with specific warnings elsewhere in this manual violates safety standards of design, manufacture, and intended use of the product. Agilent Technologies assumes no liability for the customer's failure to comply with these requirements.

Ground the equipment: For Safety Class 1 equipment (equipment having a protective earth terminal), an uninterruptible safety earth ground must be provided from the mains power source to the product input wiring terminals or supplied power cable.

DO NOT operate the product in an explosive atmosphere or in the presence of flammable gases or fumes.

For continued protection against fire, replace the line fuse(s) only with fuse(s) of the same voltage and current rating and type. DO NOT use repaired fuses or short-circuited fuse holders.

Keep away from live circuits: Operating personnel must not remove equipment covers or shields. Procedures involving the removal of covers or shields are for use by service-trained personnel only. Under certain conditions, dangerous voltages may exist even with the equipment switched off. To avoid dangerous electrical shock, DO NOT perform procedures involving cover or shield removal unless you are qualified to do so.

DO NOT operate damaged equipment: Whenever it is possible that the safety protection features built into this product have been impaired, either through physical damage, excessive moisture, or any other reason, REMOVE POWER and do not use the product until safe operation can be verified by service-trained personnel. If necessary, return the product to Agilent for service and repair to ensure that safety features are maintained.

DO NOT service or adjust alone: Do not attempt internal service or adjustment unless another person, capable of rendering first aid and resuscitation, is present.

DO NOT substitute parts or modify equipment: Because of the danger of introducing additional hazards, do not install substitute parts or perform any unauthorized modification to the product. Return the product to Agilent for service and repair to ensure that safety features are maintained.

DECLARATION OF CONFORMITY

According to ISO/IEC Guide 22 and CEN/CENELEC EN 45014

Manufacturer's Name: Agilent Technologies, Inc.
Manufacturer's Address: Measurement Products Unit
815 14th Street S.W.
Loveland, CO 80537
USA

Declares that the product

Product Name: VXI PC Controller - 450 MHz
Model Number: E9850A
Product Options: This declaration includes all options of the above product(s).

Conforms to the following product standards:

EMC	Standard	Limit
	IEC 61326-1:1997 + A1:1998 / EN 61326-1:1997 + A1:1998	
	CISPR 11:1990 / EN 55011-1991	Group 1, Class A ^[1]
	IEC 61000-4-2:1995+A1998 / EN 61000-4-2:1995	4 kV CD, 8 kV AD
	IEC 61000-4-3:1995 / EN 61000-4-3:1995	3 V/m, 80-1000 MHz
	IEC 61000-4-4:1995 / EN 61000-4-4:1995	0.5 kV signal lines, 1 kV power lines
	IEC 61000-4-5:1995 / EN 61000-4-5:1995	0.5 kV line-line, 1 kV line-ground
	IEC 61000-4-6:1996 / EN 61000-4-6:1996	3 V, 0.15-80 MHz
	IEC 61000-4-11:1994 / EN 61000-4-11:1994	1 cycle, 100%
	CISPR 22:1997/EN55022:1998 Class A	
	CISPR 24:1997/EN55024:1998	
Safety	IEC 61010-1:1990+A1:1992+A2:1995 / EN 61010-1:1993+A2:1995	
	Canada: CSA C22.2 No. 1010.1:1992	
	UL 3111-1:1994	
	IEC60950:1991+A1+A2+A3+A4	
	EN60950:1992+A1+A2+A3+A4+A11	

Conformity/Supplementary Information:

The product herewith complies with the requirements of the Low Voltage Directive 73/23/EEC and the EMC Directive 89/336/EEC (including 93/68/EEC) and carries the CE Marking accordingly (European Union).

[1] The product was tested in a typical configuration with Agilent Technologies test systems.

November 5, 1999

Date



Jim White
Quality Manager

For further information, please contact your local Agilent Technologies sales office, agent or distributor.

Rev. A (1/2000)

Trademark Information

Microsoft ®, Windows ®, and Windows® NT are registered trademarks of the Microsoft Corporation.

National Instruments™, ni.com™, LabVIEW™, CVI™, MANTIS™, MITE™, NI-488.2™, NI-488.2M™, NI-VISA™, NI-VXI™, TNT4882C™, and VXIpc™ are trademarks of the National Instruments Corporation.

All other brand and product names are trademarks or registered trademarks of their respective companies.

Manual Organization

Chapter	Description
<i>Chapter 1 - Introducing the E9850A</i>	Summarizes E9850A hardware features and driver and application software.
<i>Chapter 2 - Installing the E9850A</i>	Shows how to check your shipment, install the E9850A, and use the BIOS setup program. It also lists peripherals support information.
<i>Chapter 3 - Developing Your Application</i>	Discusses the software utilities used to develop applications that use the VISA driver.
<i>Chapter 4 - E9850A Description</i>	Provides a description of E9850A major logic blocks and LED indicators.
<i>Chapter 5 - E9850A Configuration</i>	Shows hardware and software default settings and gives guidelines to configure the E9850A.
<i>Chapter 6 - Servicing the E9850A</i>	Provides service information for the E9850A.
<i>Appendix A - E9850A Specifications</i>	Lists E9850A specifications.
<i>Appendix B - Frequently Asked Questions</i>	Answers typical questions you may have when using the E9850A.
<i>Appendix C - Customer Support</i>	Contains Agilent Technologies numbers you can use for communication about the E9850A.
<i>Appendix D - Porting Considerations</i>	Describes some porting considerations when porting from the E623xA family of Embedded Controllers to the E9850A.
<i>Appendix E - Connector Descriptions</i>	Describes front and rear panel connectors for the E9850A.
<i>Glossary</i>	Contains an alphabetical list and description of terms in this manual.
<i>Index</i>	Contains an alphabetical list of key terms and topics in this manual.

Conventions Used in This Manual

>>	The >> symbol specifies the path for nested menu items and dialog box options to a final action. For example, File>>Page Setup>>Options>>Substitute Fonts directs you to pull down the File menu, select the Page Setup item, select Options, and then select the Substitute Fonts option from the last dialog box.
<>	Angle brackets enclose the name of a key on the keyboard (<Enter>).
bold	Bold text denotes the names of menus, menu items, dialog box buttons or options, or LEDs.

<i>italic</i>	Italic text denotes variables, emphasis, a cross reference, or an introduction to a key concept. This font also denotes text that is a placeholder for a word or value that you must supply.
Arial	Text in this font denotes text or characters that you should literally enter from the keyboard, sections of code, programming examples, and syntax examples. This font is also used for the proper names of disk drives, paths, directories, programs, subprograms, subroutines, device names, functions, variables, filenames, and extensions.
Arial bold	Bold text in this font denotes the messages and responses that the computer automatically prints to the screen.
<i>Arial italics</i>	Italic text in this font denotes that you must enter the appropriate words or values in place of these items.

How to Use The Documentation Set

The E9850A Embedded VXI Controller documentation set includes printed manuals and electronic documentation in the form of Adobe Acrobat version 3.0 (or greater) portable document format (.pdf) files. The set consists of Agilent and National Instruments documentation.

Using the Agilent Documentation Set

The Agilent documentation set consists of the printed manuals shown in the following table. You can view electronic versions of some manuals using Windows NT Explorer, Internet Explorer, or the Agilent E9850A CD.

Manual	Description
<i>Agilent E9850A Embedded VXI Controller User and Service Manual</i>	Gives guidelines to install, use, and service the 9850A Embedded VXI Controller.
<i>Agilent I/O Libraries Installation and Configuration Guide</i>	Gives guidelines to install the I/O Libraries software.
<i>Agilent Standard Instrument Control Library for Windows</i>	Gives guidelines to use Agilent Standard Instrument Control Library (SICL) for Windows.

Using Windows NT Explorer

You can use any of these methods to view online versions of the manuals using Windows NT Explorer:

- Select Start>>Programs>>Agilent IO Libraries and select the manual.
- Select Agilent I/O Libraries Control Icon >>View Documentation and select the manual.
- Display Windows NT Explorer. Then, select C:\Sicln\manuals and select the manual. If you selected a different installation directory, use that path.

Using Internet Explorer

For electronic versions of this documentation, see the Agilent web site listed in *Appendix C - Customer Support*. From this site, select the manual you want to view. You can then view the manual using Adobe Acrobat 3.0 (or greater) Reader. If you do not have the Adobe Acrobat Reader necessary for viewing PDF documentation, you can download a free copy from the site.

Using the Agilent E9850A CD

To view electronic versions of applicable manuals using the Agilent E9850A CD, insert the CD into the CD-ROM drive. Assuming the CD-ROM drive is F, select the electronic version of this manual using:

```
F:\images\e985x\iolib\manuals\e985x.pdf
```

Note Since the E9850A does not have an internal CD-ROM drive, to view the CD you can connect the E9850A to a network and view the CD via the network or connect an external CD-ROM to the SCSI port on the E9850A.

Using the National Instruments Documentation Set

The National Instruments documentation set consists of printed and electronic versions of manuals shown in the following table. You can view electronic versions of the .pdf manuals using Internet Explorer, Windows NT Explorer, or the *NI-488.2 for Windows* CD.

Note Disregard the information in the *NI-VISA For Windows NT/95/98: WINNT, GWINNT, WIN95, and GWIN95 Frameworks* document. This information does not apply to the E9850A.

Printed Manuals	Description
<i> GPIB: Getting Started with Your PCI-GPIB or PCMCIA-GPIB and the GPIB Software for Windows NT </i>	Contains instructions for installing and configuring National Instruments PCI-GPIB or PCMCIA-GPIB interface and the GPIB software for Windows NT.
<i> GPIB: NI-488.2M Function Reference Manual for Win32 </i>	Describes NI-488 functions and NI-488.2 routines of the GPIB software.
<i> NI-488.2: NI-488.2 User Manual for Windows </i>	Describes the NI-488.2 software for Windows.
<i> NI-488.2M Software for Win32 Quick Ref Card </i>	NI-488.2M software quick reference.
.pdf Manuals	Description
<i> GPIB User Manual.pdf </i>	Guidelines for using GPIB.
<i> PCI-GPIB or PCMCIA-GPIB Getting Started Manual.pdf </i>	Contains instructions for installing and configuring National Instruments PCI-GPIB or PCMCIA-GPIB interface and the GPIB software for Windows NT.

<i>AT-GPIB/TNT Getting Started Manual.pdf</i>	Guidelines to get started using AT-GPIB/TNT.
<i>AT-GPIB/TNT (PnP) Getting Started Manual.pdf</i>	Guidelines to get started using AT-GPIB/TNT (PnP).
<i>NI-488.2M Function Reference Manual for Win32.pdf</i>	Describes NI-488 functions and NI-488.2 routines of the GPIB software.
<i>NI-VISA Programming Reference Manual</i>	Programming Reference for NI-VISA.
<i>NI-VISA User Manual</i>	Shows how to use NI-VISA (called VISA in this manual).

Using Windows NT Explorer To view online versions of the manuals using the Windows NT Explorer, use GPIB\Manuals[WinNT] (assuming a default directory installation). If you selected a different installation directory, use that path.

Using Internet Explorer For online versions of this documentation, go to www.ni.com/manuals/ and select the manual. You can then view the manual using Adobe Acrobat 3.0 (or later) Reader.

Related Documentation

- ANSI/IEEE Standard 1014-1987, *IEEE Standard for a Versatile Backplane Bus: VMEbus*
- ANSI/IEEE Standard 1155-1998, *IEEE VMEbus Extensions for Instrumentation: VXIbus*
- ANSI/VITA 1-1994, *VME64VXI-6, VXIbus Mainframe Extender Specification, Rev. 2.0*, VXIbus Consortium

Customer Support

Although this manual includes information for both Agilent Technologies and National Instruments products, please direct your questions for the E9850A Embedded VXI Controller to Agilent Technologies (see *Appendix C - Customer Support*).

Chapter 1

Introducing the E9850A

Chapter Overview

This chapter describes the E9850A Embedded VXI Controller and driver and application software. Chapter contents are:

- Hardware Features 13
- Software Overview 14

Hardware Features

Figure 1-1 shows the E9850A Embedded VXI Controller. See *Chapter 4 - E9850A Description* for details about the E9850A.

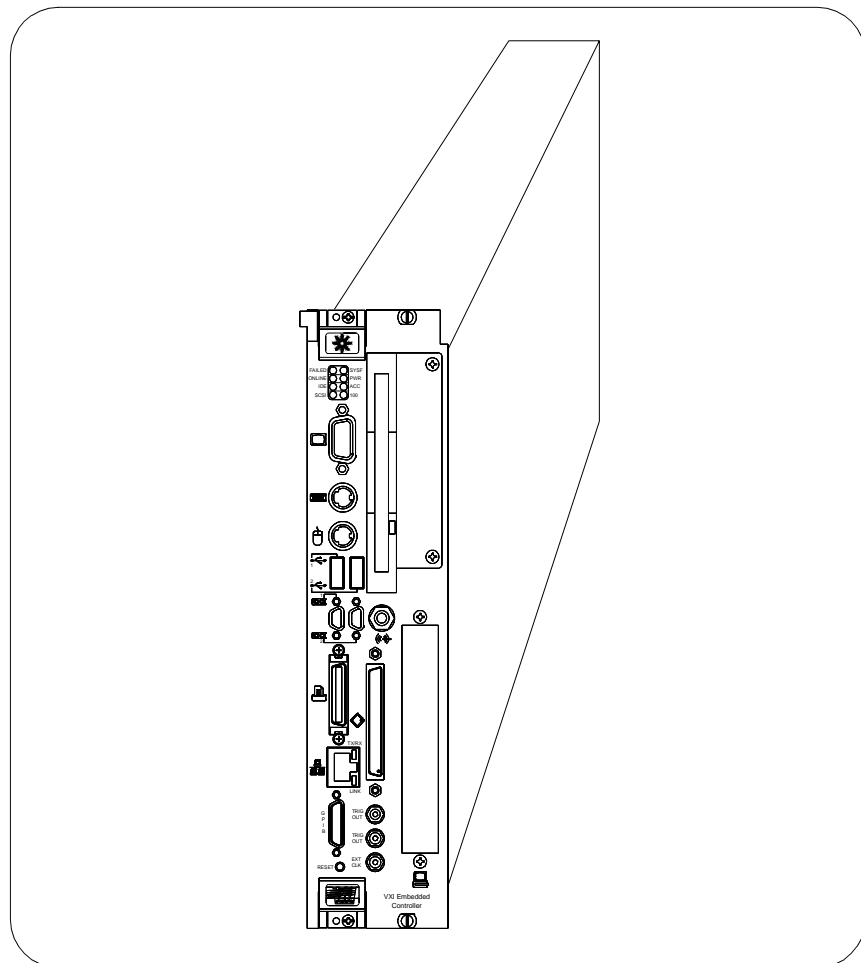

Figure 1-1. E9850A Embedded VXI Controller

The controller is a two-slot, C-size embedded controller based on the Intel Pentium® Processor architecture, the Peripheral Component Interface (PCI) bus, and the Advanced Graphics Port (AGP).

This controller is a high-performance, easy-to-use platform for controlling VXIbus systems, featuring complete VXI functionality through interactive utilities and C function calls. In addition, the controller has Ethernet capability and an IEEE 488.2 interface.

The E9850A is a custom controller that you install in two C-size slots of your VXI mainframe. An embedded controller can take full advantage of the VXI high-performance backplane capabilities and give you direct control of VXI registers, memory, interrupts, and triggers.

This controller is fully *VXIplug&play* compliant and is compatible with PC-compatible software tools, Agilent VEE, VISA, and SICL, National Instruments LabVIEW and LabWindows/CVI application software, and the VISA interface software.

The E9850A hardware includes the controller, which you install in your VXI mainframe, and the following accessories. See *Chapter 2 - Installing the E9850A* for a list of hardware, software, and documentation for the E9850A.

- COM1/2 adapter cable
- Enhanced parallel port adapter cable
- Single-shielded 2 meter GPIB cable
- AT-PS/2 Keyboard Adapter

Software Overview

There are several driver software kits developed by National Instruments and licensed by Agilent Technologies that you can use with the E9850A controller. In addition, you can use (optional) application software developed by Agilent Technologies and National Instruments.

Software Architecture

Figure 1-2 shows software architecture and related API support for the E9850A, plus applicable packaging for the software kits. See Table 2-1 for the contents of each kit.

From Figure 1-2, user APIs to National Instruments NI-VISA (called VISA in this manual) are supported by both Agilent and National Instruments. User APIs to Agilent SICL are supported by Agilent. Both SICL and VISA use NI-488 and NI-VXI for correct operation. If you want to support these APIs, contact National Instruments to purchase a support option.

The Agilent Drivers Kit includes a Windows NT and E9850A Peripheral Drivers CD and three Windows NT boot disks. The CD and boot disks can be used to restore your operating system, if required. See "Reloading the Hard Drive Image" in *Chapter 2 - Installing the E9950A* for details.

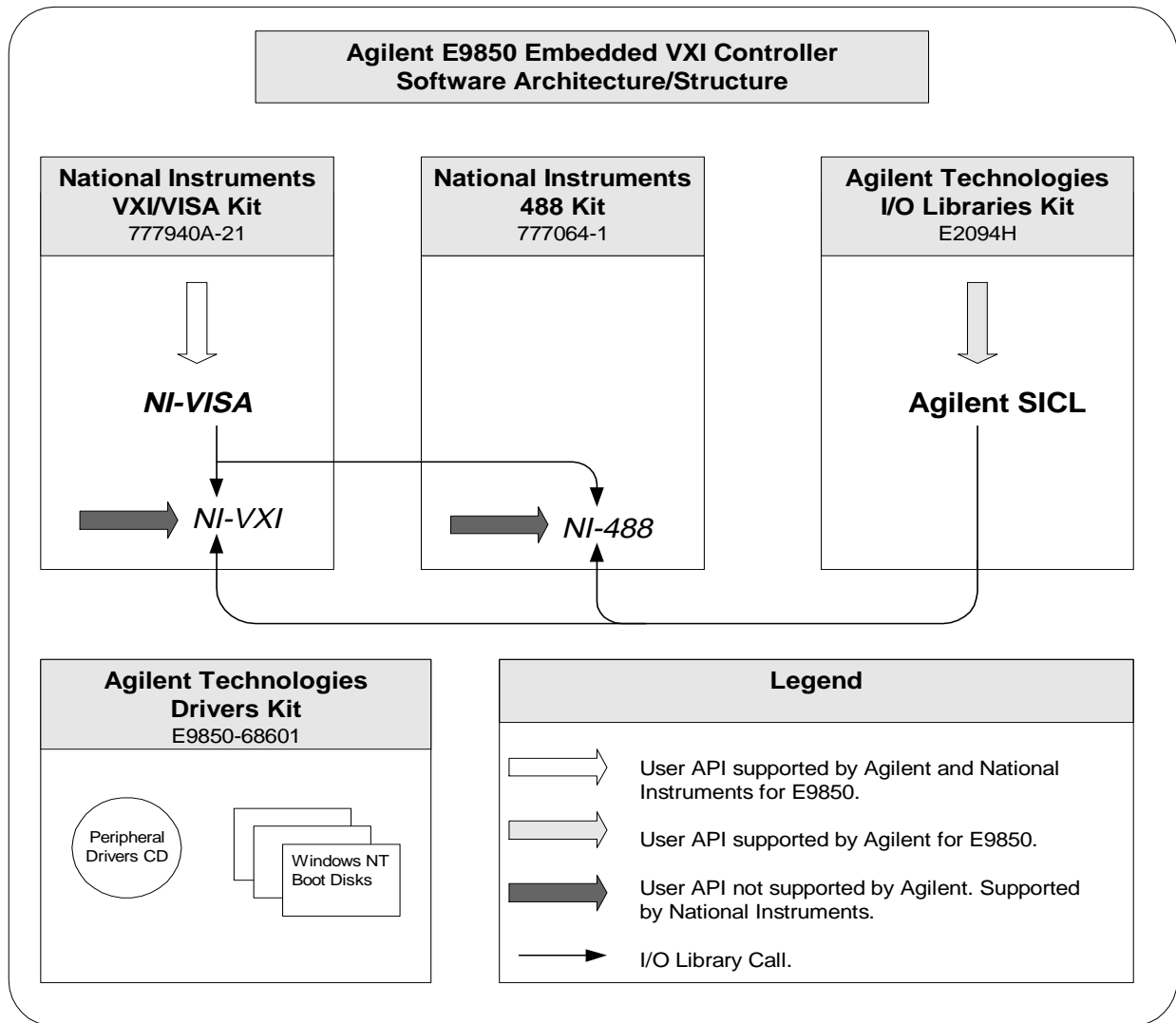

Figure 1-2. E9850A Software Architecture/Support

Driver Software

Descriptions of driver software for the E9850A follow.

SICL Standard Instrument Control Library (SICL) is an I/O library developed by Hewlett-Packard and Agilent Technologies that is portable across many I/O interfaces and systems. I/O applications using this library can be ported at the source code level from one system to another with few, or no, changes. SICL is intended for instrument I/O and C/C+ or Visual BASIC programming environments.

VISA API Virtual Instrument Software Architecture (VISA) is a uniform application programming interface (API) for communicating with and controlling serial, GPIB, VXI, and VME instruments. This API aids in creation of more portable applications and instrument drivers.

VISA (NI-VISA) is the National Instruments implementation of the VISA specification. Most current drivers written by National Instruments use NI-VISA and support Windows NT/98/95, Solaris 2, HP-UX, VxWorks, and Macintosh, as long as the appropriate system-level drivers are available for that platform.

VISA can control VXI/VME, PXI, GPIB, or serial instruments, making the appropriate driver calls depending on the type of instrument being used. VISA uses the same operations to communicate with instruments regardless of the interface type.

VISA software includes an interactive configuration and troubleshooting program, libraries of software routines for test and measurement (T&M) programming, interactive control programs for both NI-VXI and VISA, a logging utility you can use for debugging your applications, and a VXI Resource Manager. With VISA, you can run any compatible VXI *plug&play* software, including instrument drivers and executable soft front panel software.

VISA Utilities

VISA for Windows NT includes two utilities to help you configure, develop, and debug your system: T&M Explorer and NI Spy.

T&M Explorer

You can use T&M Explorer to view the test and measurement (T&M) system and configure various components. When you launch T&M Explorer, a list of VXI, GPIB and serial devices appears on your screen. To view the properties of each device (such as logical address, address space used, and primary address), right-click the device name in the list.

T&M Explorer integrates with the NI-DAQ Configuration Utility (for VXI-DAQ instruments). T&M Explorer also allows you to run Resource Manager at startup, and provides troubleshooting procedures.

NI Spy

NI Spy tracks the calls your application makes to NI T&M drivers, including NI-VXI, VISA, and NI-488.2 and highlights functions that return errors. NI Spy can also log your program's calls to these drivers.

Supported ADEs

VISA for Windows NT supports these application development environments (ADEs). Other ADEs or higher versions of the ADEs listed may not work.

- LabVIEW version 4.x, 5.x
- LabWindows/CVI version 4.x, 5.x
- Borland C/C++ version 4.5.x
- Microsoft Visual C/C++ version 4.x, 5.x, 6.x
- Microsoft Visual Basic version 4.x, 5.x

Applications Software

The following (optional) application software products are supported on the E9850A.

Agilent VEE

Agilent VEE is a graphical programming language optimized for building test and measurement applications - especially programs with operator interfaces. With Agilent VEE, you can use ActiveX Automation and Control, increase throughput, and have excellent instrument I/O flexibility controlling GPIB, VXI, serial, GPIO, PC plug-in, and LAN instruments. Agilent VEE includes a compiler, a professional development environment suited for large, complex programs, and advanced instrument management capabilities.

LabVIEW and LabWindows/CVI

You can use National Instruments LabVIEW and LabWindows/CVI application programs and instrument drivers for programming. These programs are *VXIplug&play* compliant and include GPIB, serial, and VXI instrument driver libraries. LabVIEW and LabWindows/CVI also include tools you can use for instrument control, data acquisition, analysis, and presentation development.

LabVIEW is a graphical programming environment, while LabWindows/CVI is an interactive C development environment for building test and measurement and instrument control systems. LabWindows/CVI includes interactive code-generation tools and a graphical editor for building custom user interfaces.

Notes:

Chapter 2

Installing the E9850A

Chapter Overview

This chapter contains instructions to check your shipment and to install the E9850A Embedded VXI Controller in a C-Size VXI mainframe. Chapter contents are:

- Checking Your Shipment 19
- Installing the E9850A 20
- Using the BIOS Setup Program 24
- Reloading the Hard Drive Image 24

Checking Your Shipment

The first step in installing the E9850A Embedded VXI Controller is to check the equipment you received. Table 2-1 shows the items included in the shipment. Notify Agilent (see *Appendix C - Customer Support*) of any shortages, damages, or errors in your shipment.

Table 2-1. E9850A Embedded VXI Controller Items

Item	Agilent Part Number	National Instruments Part Number	Description
Hardware			
Embedded Controller	E9850-69000	-----	E9850A VXI Controller
Printer Cable	E9850-61601	-----	IEEE 1284-2 Cable (Printer)
Serial (RS-232) Cable	E9850-61602	-----	RS-232 Cable
GPIB Cable	E9850-61603	-----	GPIB Cable
Keyboard Adapter	E9850-62101	-----	Keyboard Adapter PS-2 DIN 5F/MINI 6M
National Instruments VXI/VISA Kit (National Instruments Kit Part Number 777940A-21)			
NI-VXI/VISA CD (Version 2.05)	-----	500363F-00	NI-VXI/VISA for Embedded Controllers with Windows NT/98
National Instruments License, VXI/VISA	-----	312807A-01	NI-VXI and NI-VISA (if applicable) License Agreement
Read Me First Manual	-----	321217E-01	<i>NI-VISA For Windows NT/95/98: WINNT, GWINNT, WIN95, and GWIN95 Frameworks</i>

Table 2-1. E9850A Embedded VXI Controller Items

Item	Agilent Part Number	National Instruments Part Number	Description
National Instruments 488 Kit (National Instruments Kit Part Number 777064-1)			
NI-488.2 CD	-----	500739A-00	NI-488.2 for Windows, Version 6.0
National Instruments License, GPIB	-----	320866B-01	Driver Software License Agreement
GPIB: Getting Started Manual	-----	321289C-01	<i>GPIB: Getting Started with Your PCI-GPIB or PCMCIA-GPIB and the GPIB Software for Windows NT</i>
GPIB: NI-488.2 Reference Manual	-----	321038E-01	<i>GPIB: NI-488.2M Function Reference Manual for Win32</i>
NI-488.2 User Manual	-----	321819C-01	<i>NI-488.2: NI-488.2 User Manual for Windows</i>
NI-488.2M Quick Reference Card	-----	321039B-01	<i>NI-488.2M Quick Reference Card</i>
Agilent Manuals/Software Kit (Part Number E9850-60001)			
Read Me First Letter	E9850-90001	-----	<i>E9850A Embedded VXI Controller Read Me First Letter</i>
E9850A User and Service Manual	E9850-90000	-----	<i>E9850A Embedded VXI Controller User and Service Manual</i>
E9850-68601 Agilent Technologies Drivers Kit	E9850-13600	-----	Windows NT and E9850A Peripheral Drivers CD
	E9850-10401 E9850-10402 E9850-10403	-----	Windows NT Boot Disks
	E9850-84000	-----	Windows NT 4.0 License Agreement
Agilent I/O Libraries Kit (Part Number E2094H)			
Manual Set	E2094-60014	-----	<i>Agilent I/O Libraries Installation and Configuration Guide Agilent Standard Instrument Control Library User's Guide for Windows</i>
Software Set	E2094-60016	-----	Agilent I/O Libraries CD Software License Agreement Customer Reply Card

Installing the E9850A

This section gives general guidelines for installing the E9850A controller in a C-Size VXI mainframe. See the applicable VXI mainframe manual or technical reference manual for specific installation instructions and additional warnings and cautions.



WARNING

To protect yourself and the VXI mainframe from electrical hazards, make sure mainframe power is OFF until the E9850A is installed in the mainframe.



Caution

Electrostatic discharge can damage several components on the E9850A. To avoid such damage in handling the module, touch the antistatic plastic package to a metal part of the VXI mainframe before removing the module from the package.

Note

All software required for E9850A operation is already installed on the hard drive. The software is also included on the CDs (see Table 2-1 for a list of CDs) if you need to reinstall your software. The CDs include disk images if you need to create floppy disks.

Step 1: Prepare the Mainframe

Plug in the mainframe, **but do not turn mainframe power ON**, before installing the E9850A. The power cord grounds the mainframe and protects it from electrical damage while you are installing the module. As required, remove panels that block access to the slots.

Step 2: Check System Controller Setting (Optional)

The E9850A is factory configured to automatically detect if the module is installed in Slots 0 and 1 of a VXI mainframe (called Automatic System Controller slot detection). With Automatic System Controller slot detection, you can install the E9850A in any VXIbus mainframe slot.

As desired, you can verify that the E9850A is set for Automatic System Controller slot detection by checking the setting of jumper J12. See "Configuring the E9850A" in *Chapter 5 - E9850A Configuration* for details.



Caution

If the E9850A is not configured for automatic System Controller detection, be sure the slot you select in the VXIbus mainframe matches the E9850A configuration as either a System Controller device or a Non-System Controller device. Installing the E9850A into a slot that does not correspond with the J12 jumper setting can damage the E9850A, the VXIbus backplane, or both.

Step 3: Install the E9850A Install the E9850A into the two desired slots in the mainframe, as shown in Figure 2-1. Make sure the E9850A is fully inserted into the backplane.

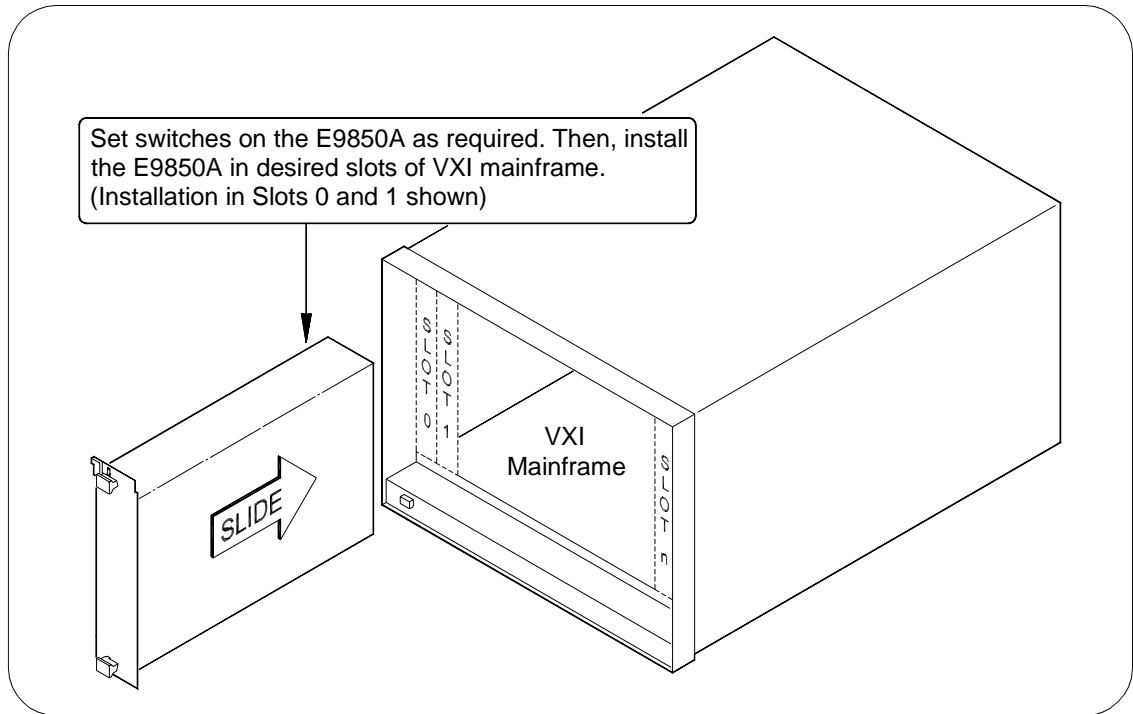

Figure 2-1. Installing the E9850A in the Mainframe

Step 4: Connect Interface Devices Connect interface devices to the appropriate front panel connectors as described in the following steps. See Figure 2-2 for front panel connector locations. See *Chapter 4 - E9850A Description* for descriptions of the connectors.

- 1 Connect the keyboard and mouse to the appropriate connectors. Use the keyboard adapter cable that you received with the shipment to adapt AT-style keyboards to the E9850A mini-DIN connector.
- 2 Connect the SVGA monitor video cable to the SVGA connector.
- 3 Connect devices to ports such as USB, COM, SCSI, Ethernet, etc. as required by your system configuration. Some ports (such as the COM and parallel ports) have adapter cables that are included in your shipment (see Table 2-1 for a list of cables).

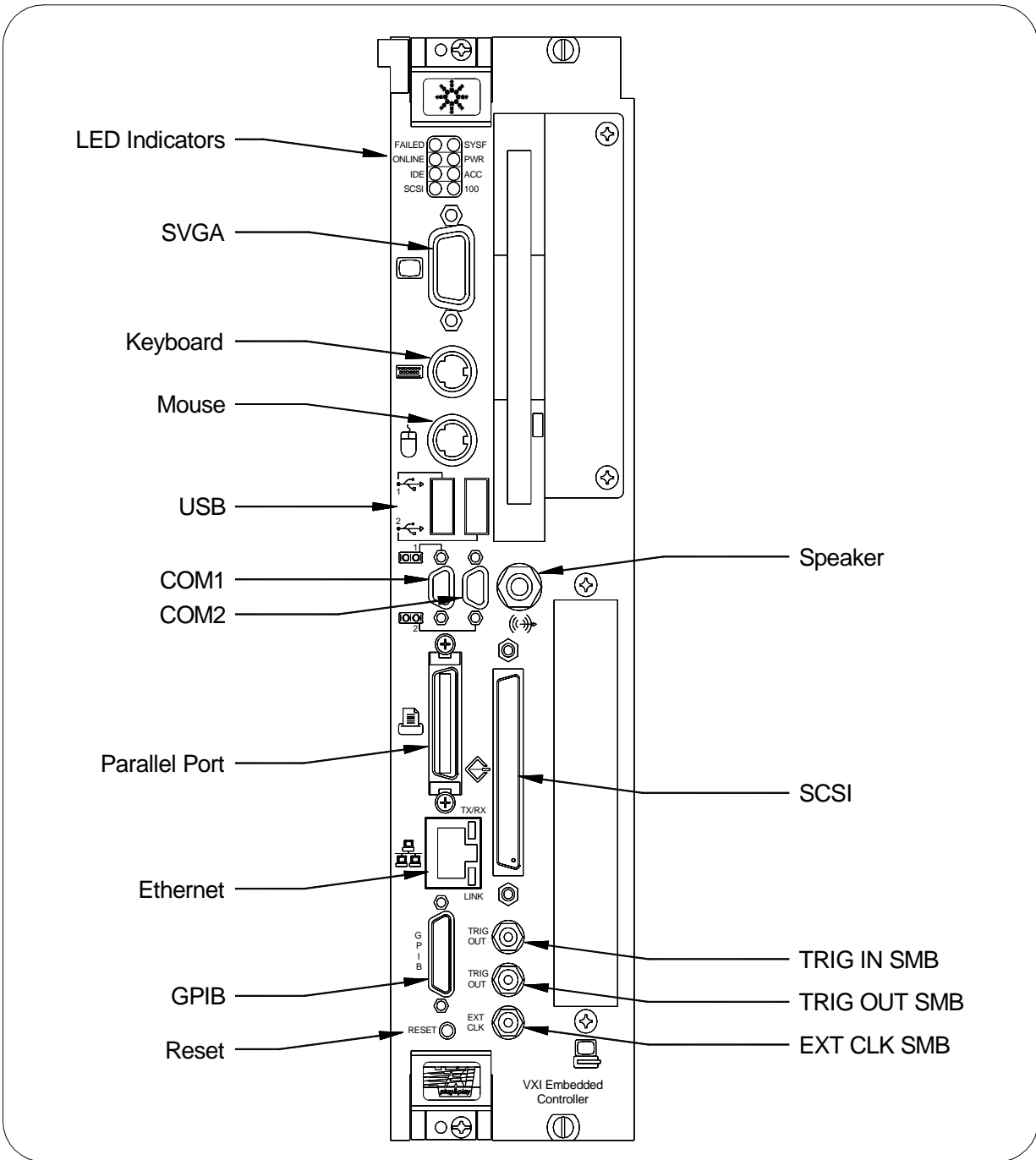

Figure 2-2. E9850A Front Panel Features

Step 5: Record System Settings (Optional)

See the *E9850A Configuration Form* in *Appendix C* if you want to record hardware settings and software versions for your installed VXI system.

Step 6: Start the E9850A

- 1 Turn the mainframe power ON. The E9850A should boot into Windows NT.

Note

While the E9850A is booting, observe the front panel LEDs. When the power-on sequence is complete, the PWR and ONLINE LEDs should be lit. If either the SYST LED or FAILED LED lights, see *Chapter 6 - Servicing the E9850A* for troubleshooting procedures.

- 2 On the first boot of the E9850A, a setup program automatically runs. Follow the prompts in the setup program to configure the controller.
- 3 When prompted for the NT serial number, enter the serial number of the operating system from the *Microsoft Windows NT Workstation Certificate of Authenticity* included with your shipment.
- 4 The E9850A is now ready for development. See *Chapter 3 - Developing Your Application* for more information.

Using the BIOS Setup Program

This section contains information on the BIOS (Basic Input Output System), the low-level interface between the hardware and PC software that configures and tests your hardware at boot up.

To enter the BIOS setup program, turn on or reboot the system. A screen appears with a series of diagnostic checks. When **Hit <D> if you want to run SETUP** appears, press the <D> key to enter the BIOS setup program. Choose the options desired and modify the settings as required to reflect system options.

To restore the default settings while inside the BIOS setup program, select either FAILSAFE Defaults or OPTIMAL Defaults. Select the optimal settings if you want to get maximum performance from the E9850A. Fail safe settings are for debugging purposes.

Reloading the Hard Drive Image

If you need to reload the hard drive image, see the `c:\sicnt\readme\ e985x.htm` file for information to recreate the hard drive image and to reinstall required peripheral drivers. This information is also available on the Agilent I/O Libraries CD in the `readme\ e985x.htm` file and on the Agilent E9850A CD.

Chapter 3

Developing Your Application

Chapter Overview

This chapter explains some ways you can start developing applications that use the VISA driver. Chapter contents are:

- Getting Started 25
- Configuration 26
- Device Interaction 27
- Programming 27
- Debugging 29

Getting Started

After verifying your system configuration, you can begin to develop your VXI/VME or VISA application.

See Latest Information Files

Please see the following files for important information that may affect your application program, including known issues, software corrections in this release, and additional information relevant to SICL and VISA development:

- C:\siclnt\readme.txt for SICL information
- C:\VXI\pnp\Winnt\nivisa\Readme.txt for VISA information

Note

You can reference the Agilent Technologies web site listed in *Appendix C - Customer Support* for driver updates, examples, and product news.

Using Configuration Utilities

Software for the E9850A includes several configuration utilities to assist you in system development. You can also access examples to learn how to use VISA for certain tasks. You can use each utility with each of the four steps of application program development: configuration, device interaction, programming, and debugging. You can access these utilities through the Windows NT Explorer Start menu. Use Start>>VXI\pnp and select the utility you want to use.

Configuration

Configuration utilities you can use are *Resman* and *T&M Explorer*.

Resman and T&M Explorer Description

Resman performs VXI Resource Manager functions described in the VXIbus specification. Functions include configuring VXI devices on the backplane for operation and allocating memory for devices that request it.

T&M Explorer presents a graphical display of your entire test and measurement system to help you configure various components.

Note

Because power cycling resets all devices, Resman must run to reconfigure the devices each time mainframe power is cycled. The default E985x configuration is to run Resman automatically when the controller boots.

T&M Explorer and Resman are designed to work together. You can run the Resource Manager through T&M Explorer by clicking the Run Resman button on the toolbar, or by selecting VXI Resource Manager from the Tools menu.

Resman reports all errors that it finds in your system to T&M Explorer. When you view your system through T&M Explorer, you can easily spot any errors in your system that Resman found.

Using Resman

Resman must be run on any system that contains VXI devices. Because VME devices normally do not have configuration registers as defined in the VXIbus specification, the Resource Manager cannot detect VME devices.

Because of this, when using systems containing a mixture of VME devices and VXI devices, you need to add your VME devices in T&M Explorer manually using the Add VME Device Wizard to reserve system resources when the Resource Manager runs.

You cannot use VISA without manually adding the VME devices to the system by using T&M Explorer and then running Resman. This is because NI-VISA uses the Resource Manager to create instrument sessions for VXI/VME device communication. If this is not an issue for you, you can skip Resman.

Using T&M Explorer

When you launch T&M Explorer, all VXI, GPIB, GPIB-VXI, and serial devices are displayed on the screen. You can add devices that cannot be detected dynamically by T&M Explorer through the Add Device Wizard in the Edit menu. Such devices include VME devices, certain GPIB devices, and serial ports.

You can view the properties (such as logical address, address space used, primary address, etc.) of each device by right-clicking the device in the tree. You can find more information about T&M Explorer by using its online help. From T&M Explorer, open the Help menu and select Help Topics.

Device Interaction

After Resman has detected and configured all VXI devices, you can view specific information on each device in your system using T&M Explorer. This utility includes a *System View* that contains a description for each device, including each VXI device's logical address.

You can interact with VXI devices using the *VISAIC* utility. You can use this utility to control your devices interactively without having to use a conventional programming language, such as Agilent VEE, LabVIEW, or LabWindows/CVI. You can launch VISAIC from the Tools menu in T&M Explorer.

VISAIC lists the available devices, similar to what T&M Explorer displays. By double-clicking a given device, you can open a VISA session and access the device through it. For more information regarding VISAIC, use the right-click help available from all panels.

Programming

The E9850A provides two programming interfaces for accessing instruments: SICL and VISA. VISA is useful when you have different types of instruments in your system (such as VXI, VME, GPIB, and serial devices) because the VISA functions have the same interface.

Programming with SICL

Standard Instrument Control Library (SICL) is a modular instrument communications library that works with a variety of computer architectures, I/O interfaces, and operating systems. Applications written in C/C++ or Visual Basic using this library can be ported at the source code level from one system to another without (or with very few) changes.

SICL uses standard, commonly used functions to communicate over a wide variety of interfaces. For example, a program written to communicate with a particular instrument on a given interface can also communicate with an equivalent instrument on a different type of interface.

This is possible because the commands are independent of the specific communications interface. SICL also provides commands to take advantage of the unique features of each type of interface. See the *Standard Instrument Control Library User's Guide* for details on SICL.

Programming with VISA

VISA grants you register-level access to VXI/VME instruments and messaging capability to message-based devices. With this interface you can service asynchronous events, such as triggers and interrupts, and also assert them. One way to learn about programming with VISA is to use the example programs in the C:\xipnp\winnt\visa\examples directory.

One way to get started is to access registers with high-level calls and to send messages with word-serial functions. The VISA examples for these tasks are called VISAhigh.c and VISAws.c. You can use other examples for more advanced techniques. Table 3-1 summarizes example program topics. See the *VISA User's Guide* for additional information.

Note T&M Explorer includes special settings you must use for low-level functions and memory sharing. See T&M Explorer online help for information on configuring these settings.

Table 3-1. VISA Examples

Category	Example
Message-Based Access	VISAws.c
High-Level Register Access	VISAhigh.c
Low-Level Register Access	VISAlow.c
Sharing Memory	VISAmem.c
Interrupt Handling	VISAint.c
Trigger Handling	VISAtrig.c

VME Support

To use VME devices in your system, configure the system to see these devices by using the Add Device Wizard in T&M Explorer. VME devices with two blocks of memory in the same address space require two entries. You can also specify which interrupt levels the device uses. VXI and VME devices cannot share interrupt levels.

You can then access the VME device from VISA just as you would a register-based VXI device, by specifying the address space and the offset from the base at which you have configured it. VISA support for VME devices includes the register access operations (both high level and low level) and the block move operations, as well as the ability to receive interrupts.

Debugging

NI Spy and *VISAIC* are utilities you can use to identify the causes of problems in your application program.

Using NI Spy

NI Spy tracks the calls your application makes to National Instruments T&M drivers including NI-VXI, NI-VISA, and NI-488.2. NI Spy highlights functions that return errors, so you can spot which functions failed during your development. NI Spy can log the calls your program makes to these drivers so you can check them for errors at your convenience.

Using VISAIC

You can also control instruments interactively using VISAIC to control and communicate with your instruments with VISA without writing a program.

See the online help for instructions on how to use VISAIC and to learn about their features. In VISAIC, you can right-click to reach What's This help and function help.

Notes:

Chapter Overview

This chapter describes the E9850A Embedded VXI Controller. Chapter contents are:

- Front Panel Features 31
- LED Indicators 33
- Functional Description 34

Front Panel Features

This section describes these E9850A front panel features. This information is relevant to the *VXIplug&play Specification VPP-8, VXI Module/Mainframe to Receiver Interconnection*. Figure 4-1 shows the front panel locations of key elements of the E9850A. See *Appendix E - Connector Descriptions* for descriptions of the front and rear panel connectors (SVGA, etc.).

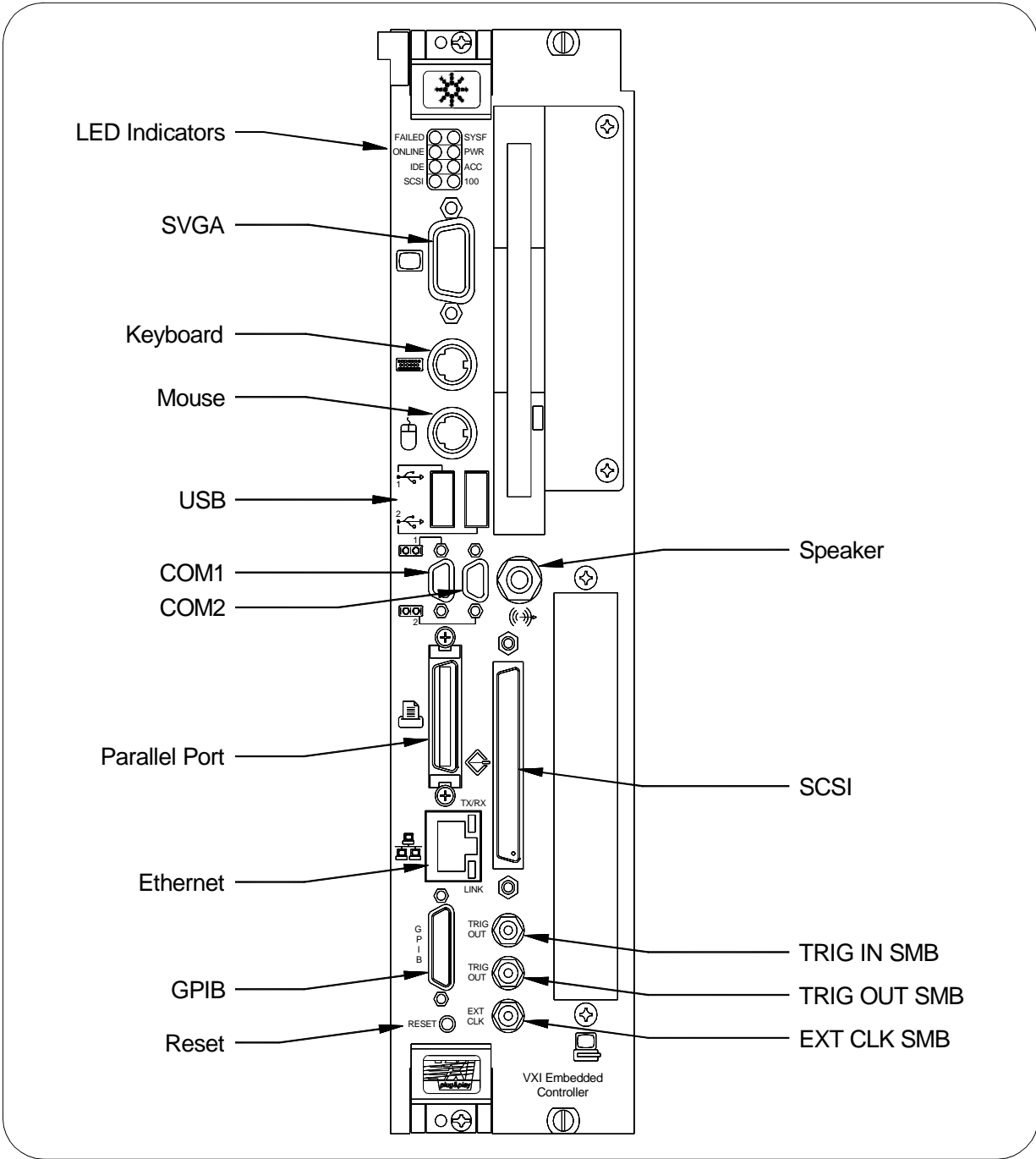

Figure 4-1. E9850A Front Panel Features

LED Indicators

This section describes the E9850A front panel LEDs. The LEDs are grouped into three sets: VXIbus Interface Status, Board Access, and Ethernet. Table 4-1 describes the E9850A LEDs.

- The VXIbus Interface Status LEDs (FAILED, SYSF, ONLINE, and PWR) show initialization stages that occur at E9850A power-on.
- The Board Access LEDs (ACC, IDE, and SCSI) indicate when board resources have been accessed.
- The Ethernet LED (100) indicates the current Ethernet connection is at 100 Mbits/s.

Table 4-1. E9850A LEDs

LED	Lights When:
VXIbus Interface Status LEDs	
SYSF	The VXIbus SYSFAIL signal is asserted. It does not necessarily mean that the E9850A is asserting SYSFAIL, only that there is a device in the system asserting SYSFAIL.
FAILED	The E9850A is driving the SYSFAIL signal. The E9850A asserts SYSFAIL when the PASSED bit in its VXIbus status register is clear. The PASSED bit is set by the power-on self configuration circuitry (POSC) when it has completed initializing the VXIbus interface.
ONLINE	The Resource Manager has successfully completed and the VXIbus interface is ready for application programs.
PWR	All the various voltages on the VXIbus backplane are present and within the tolerance range of the onboard detection circuitry. These voltages are monitored behind short circuit protection devices. If the PWR LED is not lit, it could indicate a fuse is blown or a VXIbus power supply is not working.
Board Access LEDs	
ACC	Indicates the E9850A MODID line is asserted or that another VXIbus master is accessing VXIbus shared registers or shared memory.
IDE	Indicates an access to the internal hard disk drive on the E9850A is occurring.
SCSI	Indicates an access to an external hard disk drive is occurring.
Ethernet LED	
100	Indicates the current Ethernet connection is at 100 Mbits/s.

Functional Description

This section contains functional descriptions of each major logic block on the E9850A. Figure 4-2 is a functional block diagram of the E9850A. Table 4-2 shows E9850A features.

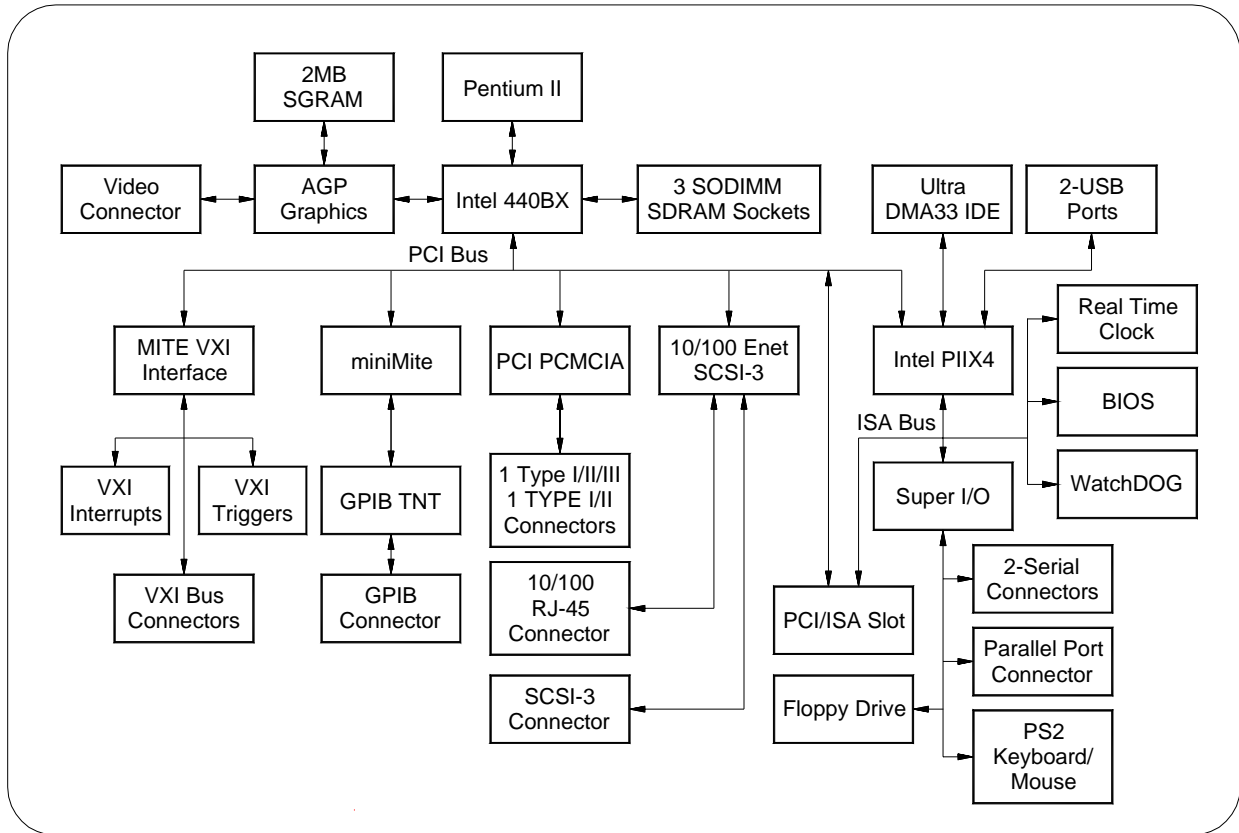

Figure 4-2. E9850A Functional Block Diagram

Table 4-2. E9850A Features

Feature	Description
Processor	The E9850A is based on the Intel Pentium® architecture. The CPU connects to the motherboard through the 100 MHz GTL+ bus. The E9850A controllers are based on Pentium technology and deliver 512 KB of level two cache.
Chip Set and SDRAM	The E9850A uses the Intel 440BX Chip Set. The 440BX connects the Pentium to the AGP port, PCI bus, and the SDRAM. The 440BX uses a 100 MHz bus for the CPU and SDRAM connections for high performance. The E9850A has three SO-DIMM sockets that can support a maximum of 384 MB of main memory. The 440BX also connects to SVGA through the AGP port. The PCI bus is then responsible for connecting the rest of the system.

Table 4-2. E9850A Features

Feature	Description
AGP Graphics Controller	<p>The E9850A uses a S3 VirgeMX AGP-based graphics controller to connect to SVGA. The AGP graphics controller is coupled to 2 MB of high-speed 64-bit SGRAM. Using the AGP port for graphics delivers a higher-speed connection between the CPU and graphics controller, off-loading traffic from the PCI bus. Some other resolutions available are:</p> <ul style="list-style-type: none"> • 640 x 460 16M colors • 800 x 600 16M colors • 1024 x 768 64K colors • 1280 x 1024 256 colors • 1600 x 1200 256 colors
10/100 Ethernet and SCSI-3	<p>The Ethernet and SCSI on the E9850A use a Symbios 53C885 dual-function PCI device to connect to 10/100Base Ethernet and Ultra Wide SCSI-3. The Ethernet function has auto negotiation to connect to 10BaseT and 100BaseTX automatically at 10 Mbits/s and 100 Mbits/s. The Ultra Wide SCSI-3 function is compatible with SCSI-1, SCSI-2, and SCSI-3. It supports 16-bit Ultra Wide SCSI transfers up to 40 Mbytes/s and 8-bit Ultra SCSI synchronous transfers at 20 Mbytes/s.</p>
Card Bus Expansion	<p>You can add third-party peripheral cards, such as additional serial ports, through one of the two Card Bus expansion slots on the front panel. The E9850A can accommodate one Type I/II/III Card Bus and one Type I/II Card Bus simultaneously. The E9850A uses the Cirrus 6730 PCI-Card Bus bridge.</p>
PCI or ISA Card Expansion	<p>The E9850A motherboard can have an expansion slot for either one full-length PCI expansion card or one 16-bit XT-height ISA bus card. You can insert either one PCI or one ISA card, but not both at the same time. See <i>Chapter 6 - Servicing the E9850A</i> for more information on using this expansion slot.</p>
IEEE 488.2	<p>The E9850A uses the miniMITE and TNT4882 ASIC (compatible with the National Instruments PCI-GPIB) to give full GPIB control of external instruments via a front-panel connector. GPIB control is fully IEEE 488.2 compatible. The GPIB interface is fully compatible with National Instruments NI-488.2 driver for a variety of operating systems. Any software using NI-488.2 will run on the E9850A.</p>
PIIX4	<p>The Intel PIIX4 is the bridge between the PCI bus and the ISA bus. It features basic PC counter/timers, interrupt controller, and DMA controllers. It also connects to the USB port and to an Ultra DMA 33 IDE interface. The Ultra DMA 33 interface is the fastest means to connect an industry-standard IDE drive to the system.</p>
Super IO	<p>The Super IO block is the interface to standard PC functions, serial ports, parallel port, floppy drive, and PS/2 keyboard and mouse. The serial ports can communicate at up to 460.8 kbits/s, and the parallel port supports all modes of EPP and ECP standards.</p>

Table 4-2. E9850A Features

Feature	Description
WatchDOG Counter/Timer	The WatchDOG is a general-purpose counter/timer that you can use to monitor running applications and reset the embedded controller or assert a signal should the system lock up. On a WatchDOG timeout, the WatchDOG can assert any of the following: reset, VXI trigger line, or VXI interrupt. The VISA software allows you to use WatchDOG. WatchDOG has a 32 kHz reference clock to clock an 8-bit prescaler that then clocks an 8-bit counter to accommodate timeouts up to 2 seconds.
Real-Time Clock	The E9850A uses a standard Y2K-compliant real-time clock with a user-replaceable battery for backing up the CMOS setting.
BIOS Code	The E9850A uses a 2 MB flash device for BIOS code. The BIOS code is based on the AWARD Modular BIOS. The BIOS code incorporates the VIDEO BIOS and SCSI BIOS in one device. The BIOS is user upgradable though a flash update utility.
Programmable Reset Circuitry	The programmable reset circuitry on the E9850A simplifies software development. You can program the circuitry to reset the PC based on VXI SYSRESET or reset the VXI bus only using NI-VXI.
VXI Voltage Monitor Circuitry	The E9850A has onboard logic to check all VXI backplane voltages. The PWR status LED indicates when all voltages are present, and provides an indication of system error. The voltage monitor can be configured to monitor all VXI power or only the voltages used by the E9850A.
Fused Power Protection	The E9850A uses resettable fuses on all voltages except +5 V. The +5 V power is a user-replaceable fuse accessible through the rear panel of the unit.
VXI Addressing	<p>The E9850A features the MITE and MANTIS custom ASICs to access VXI backplane resources. To access VXI memory or VXI devices, the E9850A uses the multiple-windowing scheme of the MITE, which makes it possible to access all of VXI address space. You can configure the VXI address windows to view specific areas of VXI memory, or you can use VISA to do this automatically.</p> <p>The MITE exports a total of eight independent VXI address windows. The VISA software driver uses three separate windows - one for VXI configuration space (A16), one for memory space (A24, A32), and one for internal use. The remaining five windows are user configurable. You can use one or all five windows and you can configure the size and location of the windows. This multiple-windowing scheme minimizes the performance penalty related to context switching of one window, as you do not need to move constantly between different address spaces.</p>
VXI Slot 0 Functionality	The E9850A computers have full VXI Slot 0 capability, including a MODID register and a CLK10 source, as required by the VXIbus specification. You can also install the E9850A in other slots and use it in Non-Slot 0 mode. The E9850A can automatically detect if it is inserted into Slot 0 and automatically enable or disable the Slot 0 onboard circuitry without switches and jumpers.

Table 4-2. E9850A Features

Feature	Description
DMA Transfers to and from VXI	<p>The E9850A can perform block-mode transfers using one of the two on-chip DMA controllers on the MITE. Controlling external VXI devices often consumes valuable CPU time because the microprocessor typically shoulders the burden of transferring data to and from devices.</p> <p>However, MITE-based VXI controllers, such as the E9850A, free up CPU processing time by moving the burden of block data transfers to one of the DMA controllers integrated in the MITE. Instead of the computer microprocessor transferring the data and/or commands, the VISA software uses the MITE ASIC to execute the block data transfers. While the MITE transfers the data, the processor can perform application-specific tasks, such as data presentation and analysis.</p>
External VXI CLK10 Synchronization	<p>The E9850A has an SMB connector on the front panel for an external clock. Onboard programmable logic can configure the E9850A to drive its 10 MHz VXI CLK10 signal to this connector as an output or to use this connector as an input for the 10 MHz VXI CLK10 signal. You can configure multiple mainframes to operate from single 10 MHz system clock. All CLK10 routing features are controllable through software.</p>
VXI Trigger Lines	<p>The E9850A gives full hardware and software control over the VXI trigger lines. The E9850A has two SMB trigger I/O connectors on its front panel for routing any TTL trigger line between the backplane and external devices. The MANTIS ASIC interface provides the complete E9850A VXI interface to the outer rows of the P2 backplane connector in a single chip. The E9850A can respond to all VXI-defined protocols on all P2 TTL and ECL trigger lines at the same time.</p> <p>The MANTIS features an internal cross-matrix switching system for routing between lines as well as to and from the front panel and onboard clocks. An internal counter gives sophisticated counting of events and interrupting on trigger edges and pulses, as well as generating pulse trains, variable length pulses, and pulse stretching.</p>
VXI Interrupts	<p>The E9850A can function as an interrupter and an interrupt handler for any or all of the VXIbus interrupt lines in a VXI mainframe. The E9850A works with both Release on Acknowledge (ROAK) and Release on Register Access (RORA) devices. All interrupts are routed to the microprocessor. The E9850A can also detect other VXIbus conditions, including assertion of ACFAIL, SYSFAIL, and BERR.</p>

Notes:

Chapter 5

E9850A Configuration

Chapter Overview

This chapter shows default settings and configuration procedures for the E9850A Embedded VXI Controller. Chapter contents are:

- Hardware Default Settings 39
- T&M Explorer Default Settings 41
- Configuring the E9850A 42

Hardware Default Settings

Figure 5-1 shows the location of user-configurable jumpers and switches on the E9850A and the location of the serial and assembly numbers. Table 5-1 identifies the default setting and optional settings for each item.

Note Please do not adjust any jumpers or switches not listed in Table 5-1 or not documented in this manual unless directed by Agilent Technologies.

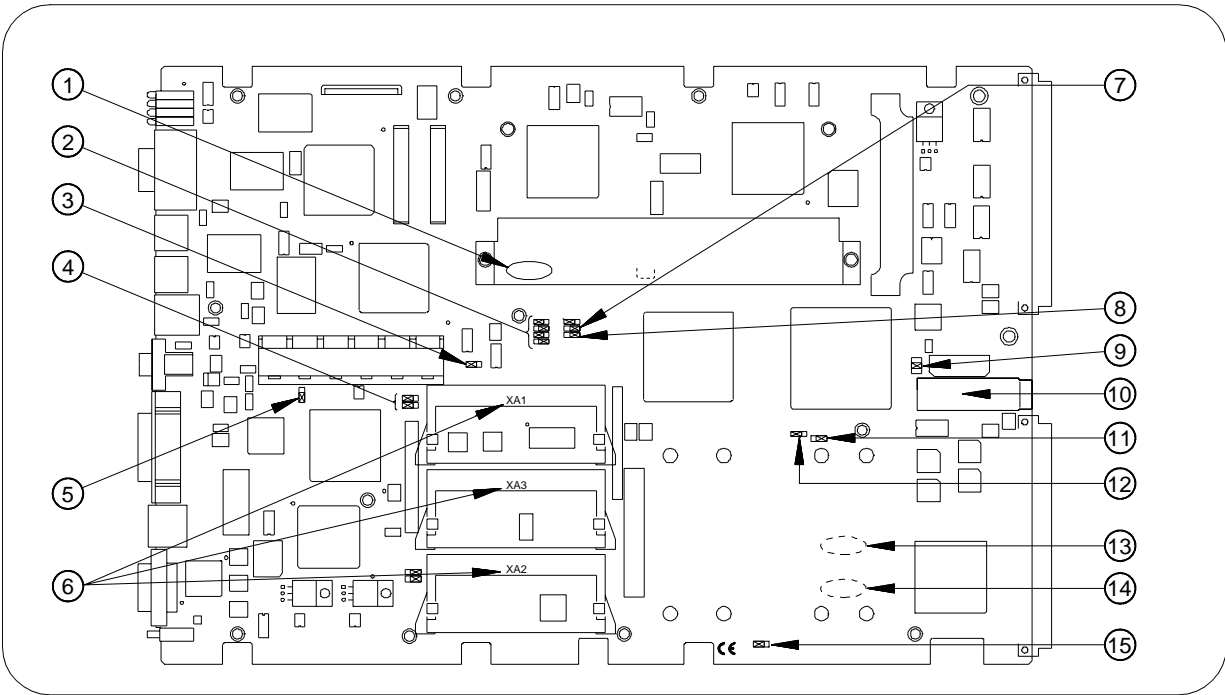

Figure 5-1. E9850A Switch/Jumper Locations

Table 5-1. E9850A Hardware Default Settings

No.	Title	Jumper/Switch	Default Setting	Optional Settings
1	Ethernet Address	-----	-----	-----
2	CPU Bus Factor	W1, W3, W5, W7	CPU bus factor	-----
3	Flash Protect	W8	Flash write enable	Flash Protection
4	SCSI Termination	W11-W12	Enable 16-bit SCSI term	SCSI Termination
5	Ethernet Serial EEPROM Enable	W10	Enable Ethernet serial EEPROM configuration	Disable Ethernet Serial EEPROM Configuration
6	SO-DIMM Sockets	-----	-----	-----
7	Bus Speed	W4	100 MHz CPU bus speed	66 MHz bus speed
8	CMOS	W6	Normal CMOS operation	Clear CMOS
9	Slot Detection	J12	Enable Slot 0 detection	Force Slot 0/Force Non-Slot 0
10	Fuse	-----	-----	-----
11	MITE User Config	S1	MITE user configuration	MITE Factory Configuration
12	MITE Config Enable	S2	Enable MITE self-config.	Disable MITE self-config.
13	Assembly Number	-----	-----	-----
14	Serial Number	-----	-----	-----
15	Voltage Monitor	W15	Voltage monitor req. voltages	Voltage monitor all voltages

T&M Explorer Default Settings

Table 5-2 summarizes default settings for the E9850A T&M Explorer.

Table 5-2. T&M Explorer Default Settings

Editor Field	Default Setting
Device Tab	
Logical Address	0
Device Class	Message-Based
Size of Servant Area	0
Number of Handlers	1
Number of Interrupters	0
Shared Memory Tab	
Memory Sharing	A32
Shared RAM Size	64 kB (When Sharing Memory)
Reserved Physical Memory	64 kB (When Sharing Memory)
Lower-Half Window Byte Swapping	Disabled
Upper-Half Window Byte Swapping	Disabled
Map Upper and Lower Halves at the Same PCI Address	Disabled
PCI Tab	
Low-Level Register Access API Support	Enabled
User Window Size	128 MB

Configuring the E9850A

This section gives guidelines to configure the E9850A, including the following items. As applicable, the switch(es)/jumper(s) used for the configuration are shown in parentheses. See Figure 5-1 for switch/jumper locations. The section contents are:

- System Controller Operation (J12)
- Power-On Self-Configuration (S2)
- MITE EEPROM Settings (S1)
- SCSI Termination (W11, W12)

- System CMOS (W6)
- CPU Bus Speed (W4)
- CPU Bus Factor (W1, W3, W5, W8)
- Flash Protection (W8)

- Ethernet Serial EEPROM (W10)
- Voltage Monitor (W15)
- CLK10 Routing and Termination (T&M Explorer)
- Trigger Input Termination (T&M Explorer)
- Using WatchDOG (T&M Explorer)

Note For each operation that requires hardware changes, you will need to do these steps, although they may not be listed in the procedure:

1. Turn mainframe power OFF.
2. Remove the E9850A from the mainframe.
3. Remove the cover from the E9850A.
4. Set jumper/switch position as required.
5. Replace the E9850A cover.
6. Reinstall the E9850A in the mainframe.
7. Turn mainframe power ON.



WARNING

To protect yourself and the mainframe from electrical hazards, turn mainframe power OFF before removing the E9850A and leave mainframe power OFF until the E9850A is replaced in the mainframe.

System Controller Operation (J12)

The E9850A is factory configured to detect automatically whether the module is installed in Slot 0 of a VXIbus mainframe. This is called Automatic System Controller Slot Detection. With Automatic System Controller Slot Detection set, you can install the E9850A in any VXIbus slot.

As desired, you can set jumper J12 to configure the E9850A for Automatic System Controller Slot Detection, System Controller Operation, or Non-System Controller Operation, as shown in Figure 5-2.



WARNING

Do not install a device configured for System Controller Operation into a slot without first reconfiguring the device to Non-System Controller Operation or to Automatic System Controller Slot Detection. Not doing this could result in damage to the device, the VXIbus backplane, or both.

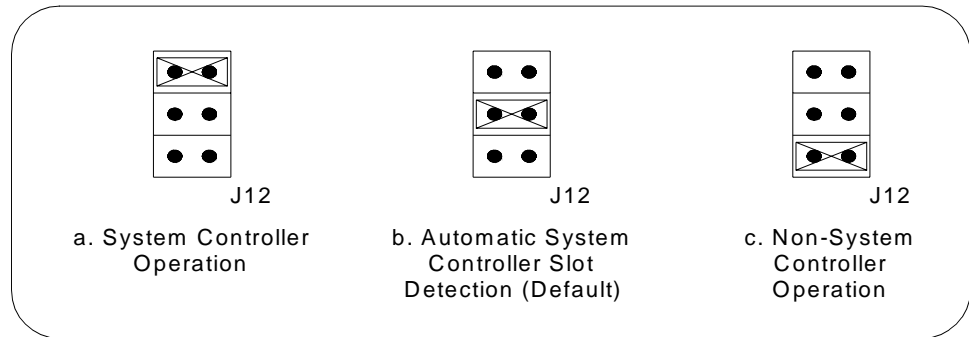

Figure 5-2. System Controller Operation Switch Settings

When the E9850A is installed in slots 0 and 1 of a VXI system, it becomes the VXIbus System Controller. In this role, the E9850A has VXIbus Data Transfer Bus Arbiter circuitry that accepts bus requests on all four VXIbus request levels, prioritizes the requests, and grants the bus to the highest priority requester.

As VXIbus System Controller, the E9850A also drives the 16 MHz VXIbus system clock by an onboard 16 MHz oscillator. Also, when installed in slots 0 and 1, the E9850A drives the 10 MHz signal CLK10 on a differential ECL output. When not installed in slots 0 and 1, the E9850A receives only the CLK10 signal.

Power-On Self-Configuration (S2)

The E9850A has a MITE EEPROM that stores default register values for the VXI circuitry that are loaded when the computer is powered on. The values are read from the EEPROM program, the PCI interface, and the VXIbus registers so the VXI interface is ready to respond to Resource Manager accesses within 5 seconds of SYSRST* deasserting.

You can disable this power-on self-configuration (POSC) circuit by changing switch S2. Although this makes the VXI circuitry unusable, it is sometimes helpful in debugging address and interrupt conflicts with add-in boards. In general, however, you should leave switch S2 in its factory-default setting. Figure 5-3 shows S2 settings.

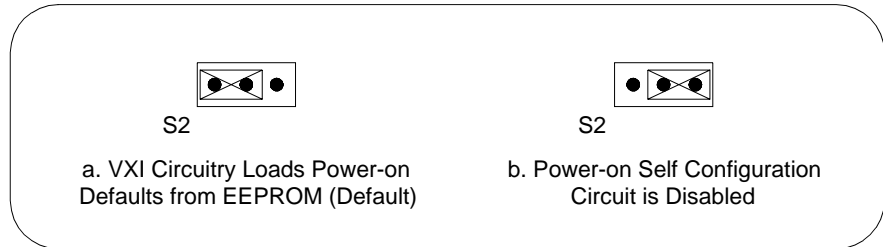

Figure 5-3. Power-On Self-Configuration Status

MITE EEPROM Settings (S1)

The MITE EEPROM is divided into two halves: one half is factory configured and the other half is user configurable. You can use switch S1 to set whether the E9850A boots from the factory-configured half or the user-modified settings. In default setting, the E9850A boots from the user-configurable half. See Figure 5-4 for S1 settings.

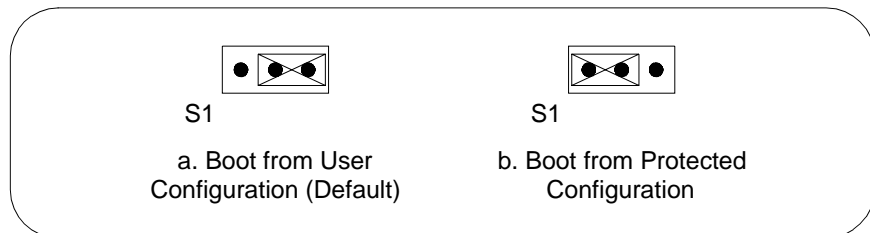

Figure 5-4. EEPROM Configuration Settings

Switch S1 is useful if the user-configured half of the EEPROM becomes corrupted to an extent that the E9850A boots to an unusable state. By changing the switch S1 setting, you can return to the factory configuration.

Certain EEPROM configurations, including invalid configurations, can lock up the computer while it is booting. Generally, only the size and location of the memory windows cause the E9850A to lock up your system.

For example, many PCI-based computers will not boot if a board in the system requests more memory space than the computer can allocate. If you encounter this situation, you should reduce the size of the E9850A user window. The EEPROM can become corrupted if the E9850A is shut down while it is updating the EEPROM.

If this situation occurs, use T&M Explorer under Windows NT to edit the configuration of the E9850A. Some of these settings are stored in files read by software, while other settings are stored directly in the E9850A EEPROM. If the computer still locks up after reconfiguration, perform these steps:

- 1 Turn mainframe power OFF.
- 2 Change switch S1 to the position shown in Figure 5-4b to restore the factory configuration.
- 3 Turn mainframe power ON. The E9850A should boot this time because the factory-default configuration is being used for initialization.
- 4 Run your software configuration utility to readjust the E9850A configuration.
- 5 After saving the configuration, exit Windows and turn mainframe power OFF.
- 6 Change switch S1 to the default position, as shown in Figure 5-4a.
- 7 Turn mainframe power ON. If the E9850A does not boot with this configuration, you will need to repeat these steps, modifying your configuration until a final configuration is reached.

SCSI Termination (W11, W12)

The E9850A uses active termination on the SCSI-3 bus. Because the E9850A is always an end device, you should not need to disable the termination. However, for informational purposes, Figure 5-5 shows the W11 and W12 jumper settings for both enabled and disabled termination.

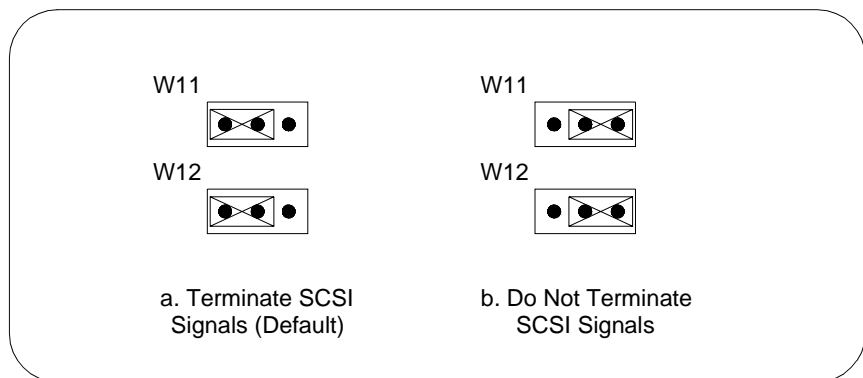

Figure 5-5. SCSI Termination

System CMOS (W6)

The E9850A contains a backed-up memory used to store BIOS defaults and configuration information. To clear the CMOS contents:

- 1 Turn mainframe power OFF, remove the E9850A, and remove the E9850A cover.
- 2 Place the jumper as shown in Figure 5-6b to short the pins of W6.



Caution

Do not keep these two pins shorted, because CMOS memory cannot be sustained when the power is turned off in this state.

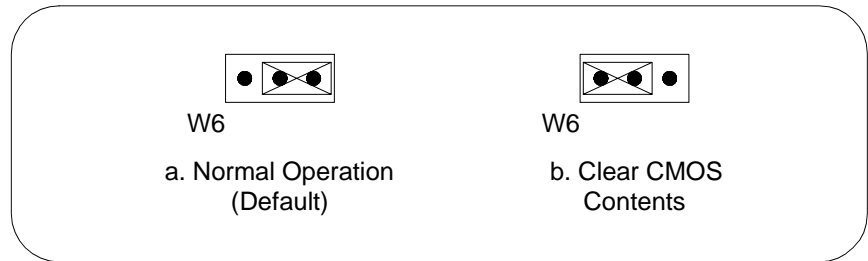

Figure 5-6. System CMOS

- 3 Replace the E9850A cover. Then, replace the E9850A and turn mainframe power ON. The screen should briefly appear and then go blank.
- 4 Turn mainframe power OFF, remove the E9850A, and remove the E9850A cover.
- 5 Replace the W6 jumper as shown in Figure 5-6a to restore normal operation.
- 6 Replace the E9850A cover. Then, replace the E9850A and turn mainframe power ON.

CPU Bus Speed (W4)

The E9850A supports CPU bus speeds at 66 MHz and 100 MHz. Under most circumstances, 100 MHz delivers the best performance. If you want to use a 66 MHz bus speed, set jumper W4 as shown in Figure 5-7a.

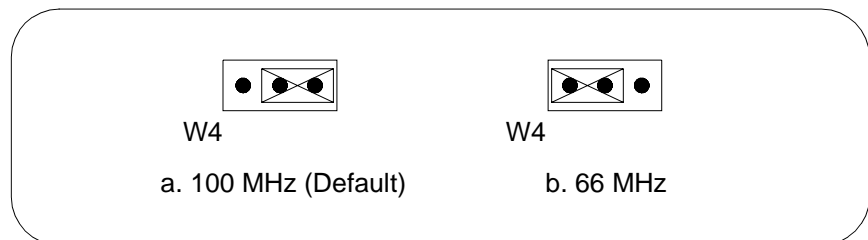

Figure 5-7. CPU Bus Speed Configuration

CPU Bus Factor (W1, W3, W5, W7)

Figure 5-8 shows currently supported (Pentium II) CPU speeds and bus factors. Contact Agilent Technologies for jumper settings for new CPUs.

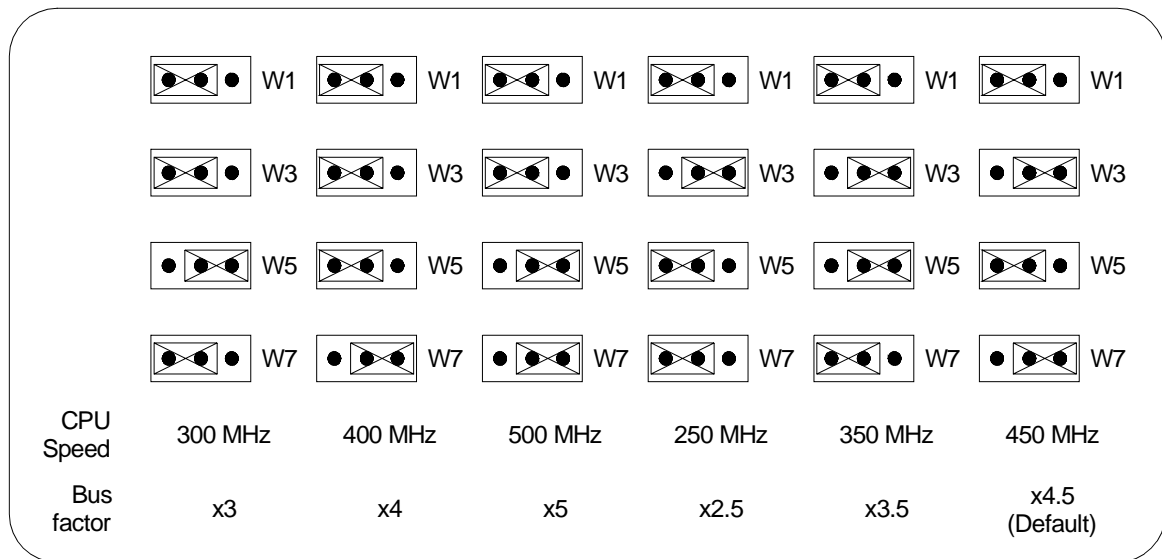

Figure 5-8. CPU Bus Factor Jumper Settings

Flash Protection (W8)

The E9850A uses a standard 2M bit flash with write protection. Under normal use, this jumper should not be changed. Figure 5-9 shows default and disabled settings for the Flash Protection Jumper, W8.

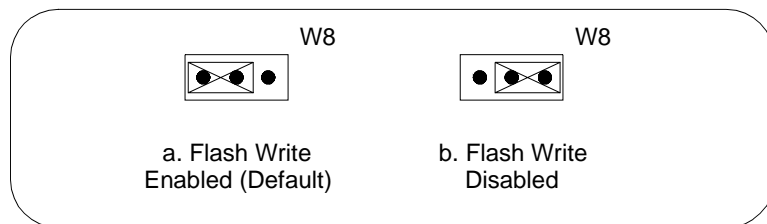

Figure 5-9. Flash Protection Jumper Settings

Ethernet Serial EEPROM (W10)

A serial EEPROM loads the Ethernet power-on settings. Under normal use, this jumper should not be changed. Figure 5-10 shows default and disabled settings for the Ethernet Serial EEPROM Jumper, W10.

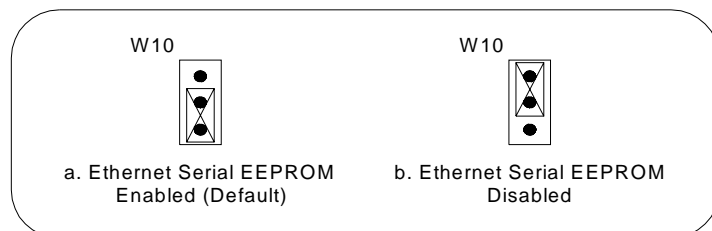

Figure 5-10. Ethernet Serial EEPROM Settings

Voltage Monitor (W15)

You can monitor all backplane voltages or only those required to boot the E9850A by setting the Voltage Monitor Jumper, W15, as shown in Figure 5-11.

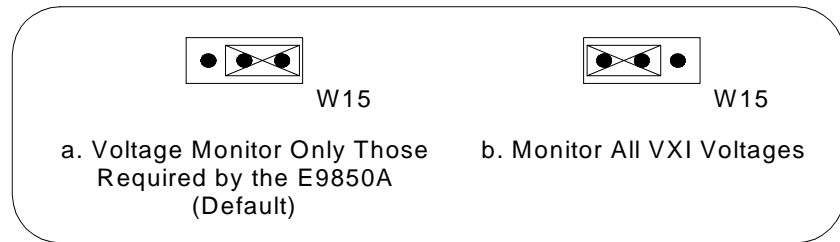

Figure 5-11. Voltage Monitor Settings

CLK10 Routing and Termination (T&M Explorer)

When the E9850A is installed in Slot 0 of your mainframe, it supplies the VXIbus CLK10 signal. The E9850A can use two different sources to generate this signal: an onboard oscillator or the external CLK SMB connector. The E9850A can also be configured to drive the external CLK10 SMB from the VXIbus CLK10 signal when in non-slot 0.

The E9850A has onboard logic that helps configure the VXIbus CLK10 routing and termination. You can route the CLK10 signal from the front panel to the backplane or from the backplane to the front panel. You also have the option to add a 50 W termination to the signal. All settings for CLK10 routing and termination are set via software. Use T&M Explorer to configure these settings.

Trigger Input Termination (T&M Explorer)

You can terminate the external trigger input SMB with 50 W to ground to match the driving source, as required. Use T&M Explorer to set this option.

Using WatchDOG (T&M Explorer)

The WatchDOG is an onboard, general-purpose counter/timer you can use to monitor running applications and reset the embedded controller or assert a signal if the system locks up. All WatchDOG timer features are configured through T&M Explorer.

Chapter 6

Servicing the E9850A

Chapter Overview

This chapter contains information for troubleshooting the E9850A and replacing/installing selected components of the E9850A Embedded VXI controller. Chapter contents are:

- Replaceable Parts List 49
- Exchanging the E9850A 50
- Troubleshooting Techniques 51
- Repair/Installation Guidelines 54



WARNING

Repair is limited to replacements of the components listed in Table 6-1. Repairs/installation must be performed at a static-controlled workstation by trained service personnel only.

Replaceable Parts List

These replacement/exchange parts are available from Agilent Technologies under the part numbers shown in Table 6-1. Contact Agilent Technologies (see *Appendix C - Customer Support*) to obtain replacement/exchange parts.

Table 6-1. E9850A Replaceable Part Numbers

Component	Agilent Part Number
Exchange Assemblies	
Rebuilt E9850A VXI Controller with Windows/NT Loaded (exchange only)	E9850-69000
Replacement 4 GB internal hard drive with Windows/NT loaded (exchange only)	E9850-00101
Replaceable Parts	
Type 3AG, 15A, Slow Blow main power fuse for VXI +5 V	2110-0025
128 MB SO-DIMM SDRAM	E9850-xxxxx
IEEE 1284-2 Printer Cable	E9850-61601
RS-232 Cable	E9850-61602
GPIB Cable	E9850-61603
Keyboard/Adapter PS-2 DIN 5F/MINI 6M	E9850-62102

Exchanging the E9850A

If your E9850A does not operate properly, the *only* authorized user repair is to replace the main power fuse (see "Changing the Main Power Fuse") and/or the hard drive (see "Replacing the Hard Drive"). If replacing the fuse and/or hard drive does not return the E9850A to full operation, you *must* return your E9850A to Agilent Technologies for repair or for an exchange unit.

To exchange your E9850A for repair or for a replacement E9850A, contact Agilent Technologies at the addresses/numbers listed in *Appendix C - Customer Support*. However, before returning your E9850A, take the following steps.

Note To perform periodic backup of system data and application software or to load or restore software on the E9850A, you will need an SCSI-based software backup peripheral such as an external CD-R drive, CD-RW drive, or tape backup drive.

1. Back Up Software Applications and/or Data

Software and data backup recovery are the sole responsibility of the customer. Agilent Technologies assumes no responsibility for loss or corruption of software applications or data. Please be sure all software applications and/or data are properly backed up before returning your E9850A.

2. Reload Hard Drive Image (as Required)

Before returning your E9850A, reload the hard drive image to see if this solves the problem. See "Reloading the Hard Drive Image" in *Chapter 2 - Installing the E9850A* for information to recreate the hard drive image and to reinstall required peripheral drivers. If this does not solve the problem, proceed to steps 2 and 3 before returning your E9850A.

3. Remove Customer-Installed Features

The E9850A is shipped with a standard feature set of I/O ports and RAM. However, additional I/O ports and/or additional RAM may have been added. Before returning your E9850A to Agilent Technologies, please ensure that all customer installed, nonstandard features are removed. You can then reinstall these features in your replacement E9850A.

Troubleshooting Techniques

Table 6-2 shows a system startup cycle and possible points of failure up to, and including, the state at which the ONLINE LED is asserted.

Table 6-2. VXIbus Interface Status LEDs and System Startup Status

Step	LEDs Lit	Status	Possible Problem if E9850A Fails
1	None	System just turned on.	E9850A is not receiving power or fuse is blown.
2	PWR	System just turned on.	E9850A starting to boot. All voltages present.
3	PWR, FAILED, SYSF	Asserting FAIL because VXIbus interface has not yet been initialized.	Power-on self configuration (POSC) cannot execute due to problems with system reset or the POSCEN switch is incorrectly configured.
4	PWR	POSC cycles are complete. VXI port is ready to respond to Resource Manager inquiries.	POSC completed successfully. However, the Resource Manager either hung or was not executed.
5	PWR, ONLINE	Resource Manager has been executed. The VXI software can communicate with VXIbus circuitry.	Resource Manager interface initialized successfully.

If either the SYSF or FAILED LED remains lit, perform the following steps:

1. Power off the mainframe.
2. Remove all other modules from the mainframe.
3. Make sure the E9850A switch and jumper settings are correct.
4. Make sure the E9850A is seated properly in the mainframe.
5. Power on the mainframe and observe whether the SYSF and FAILED LEDs become unlit some time before the operating system boots.

Repair/Installation Guidelines

This section gives guidelines to repair or install E9850A components, including:

- Cleaning Instructions
- Changing Main Power Fuse
- Removing the E9850A Cover
- Adding Additional RAM
- Replacing the Hard Drive
- Installing I/O Expansion Cards



WARNING

There are no user-serviceable parts inside the E9850A. Repair is limited to replacement of the main power fuse. Repairs/installations must be performed at a static-controlled workstation by trained service personnel only.

Cleaning Instructions

The only cleaning required for the E9850A mainframe is to wipe the exterior of the unit with a clean, damp cloth and dry with a clean, dry cloth. Do not attempt to clean any interior parts of the E9850A.

Changing Main Power Fuse

The E9850A is equipped with a user-replaceable fuse on the main power, +5 V from the VXibus. All other voltages are fused with resettable-style circuit breakers that do not require user intervention. When a short circuit condition is removed, these circuit breakers automatically reset themselves.

Because the +5 V main power current is too high for resettable fuse technology, use a replaceable fuse of type 3AG, 15A slow blow. You can replace this fuse without removing the cover. The fuse is accessible via the rear of the E9850A as shown in Figure 6-1.

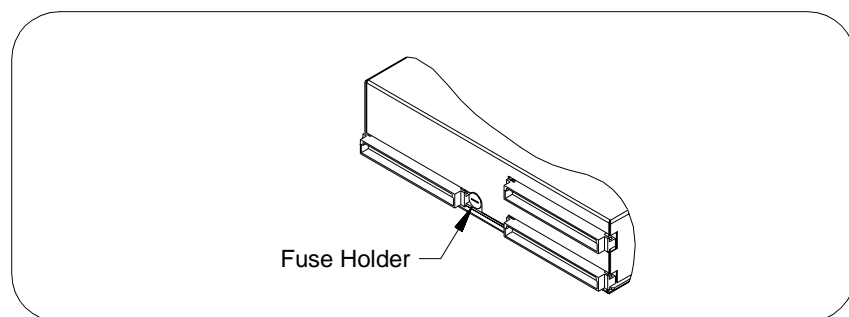

Figure 6-1. Main Power Fuse Replacement

To replace this fuse:

1. Turn mainframe power OFF and remove the E9850A from the mainframe.
2. Using a small flathead screwdriver, turn the fuse holder counter-clockwise until the fuse holder can be removed from the E9850A.
3. Replace the fuse with the same type fuse.



Caution Do not replace the fuse with a higher-rated fuse. This could cause damage to the E9850A, the VXI mainframe, or both.

4. Fully insert the fuse and holder into the fuse housing.
5. Turn the fuse holder clockwise until the fuse holder is flush with the fuse housing.
6. Reinstall the E9850A into the mainframe and turn mainframe power ON. If the fuse continues to blow, contact Agilent Technologies.

Removing the E9850A Cover

To add additional RAM, change switch/jumper settings, replace the hard drive, or install I/O expansion card panels, you will first need to remove the E9850A cover as shown in Figure 6-2.

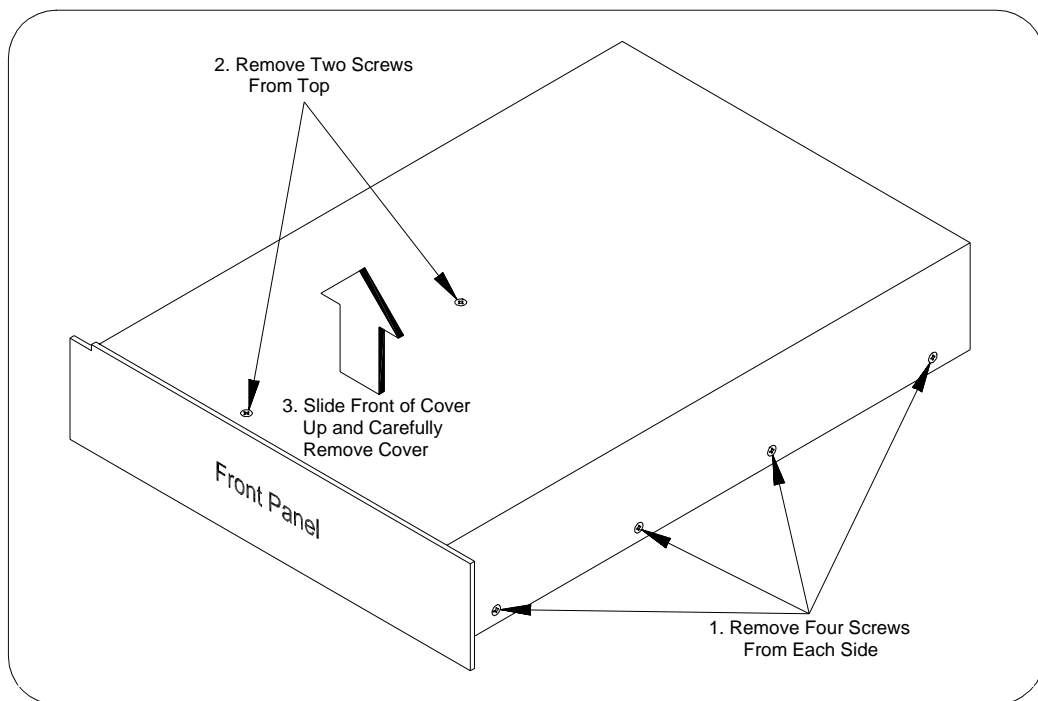

Figure 6-2. Removing the E9850A Cover

To remove the cover:

1. Turn mainframe power OFF and remove the E9850A from the mainframe.
2. Use a Phillips-head screwdriver to remove the 10 flat head screws (four on each side and two on the top of the cover).
3. Slide the front of the cover upward and then remove the cover.

Adding Additional RAM

The E9850A uses 144-pin 100 MHz (PC100) SDRAM and supports 16, 32, 64, and 128 MB SO-DIMMs for a total of 384 MB maximum. To add RAM to the E9850A:

1. Turn mainframe power OFF, remove the E9850A and remove the E9850A cover (see Figure 6-2).
2. Add SO-DIMM modules to the empty SO-DIMM sockets (see Figure 5-1 in *Chapter 5 - E9850A Configuration* for socket locations). These SO-DIMMs are recommended for use with the E9850A controller (SDRAM):
 - 64 MB: 8 MB x 64 SO-DIMMs - 10 ns, 1.05 in. max.
 - 128 MB: 16 MB x 64 SO-DIMMs - 10 ns, 1.05 in. max.

Note

Agilent Technologies has tested and verified that E9850-xxxxx 128 MB SO-DIMMs work with the E9850A. Other off-the-shelf SO-DIMM modules are not guaranteed to work properly.

Replacing the Hard Drive

If the hard drive fails, you may either return the entire E9850A to Agilent Technologies for exchange (see "Exchanging the E9850A") or replace the hard drive. To replace the hard drive:

1. Turn mainframe power OFF and remove the E9850A from the mainframe.
2. Remove the E9850A cover. See "Removing the E9850A Cover" for details.
3. Remove the hard drive from the E9850A (see Figure 6-3).
4. Replace the hard drive.
5. Replace the E9850A cover, reinstall the E9850A in the mainframe, and turn mainframe power ON.

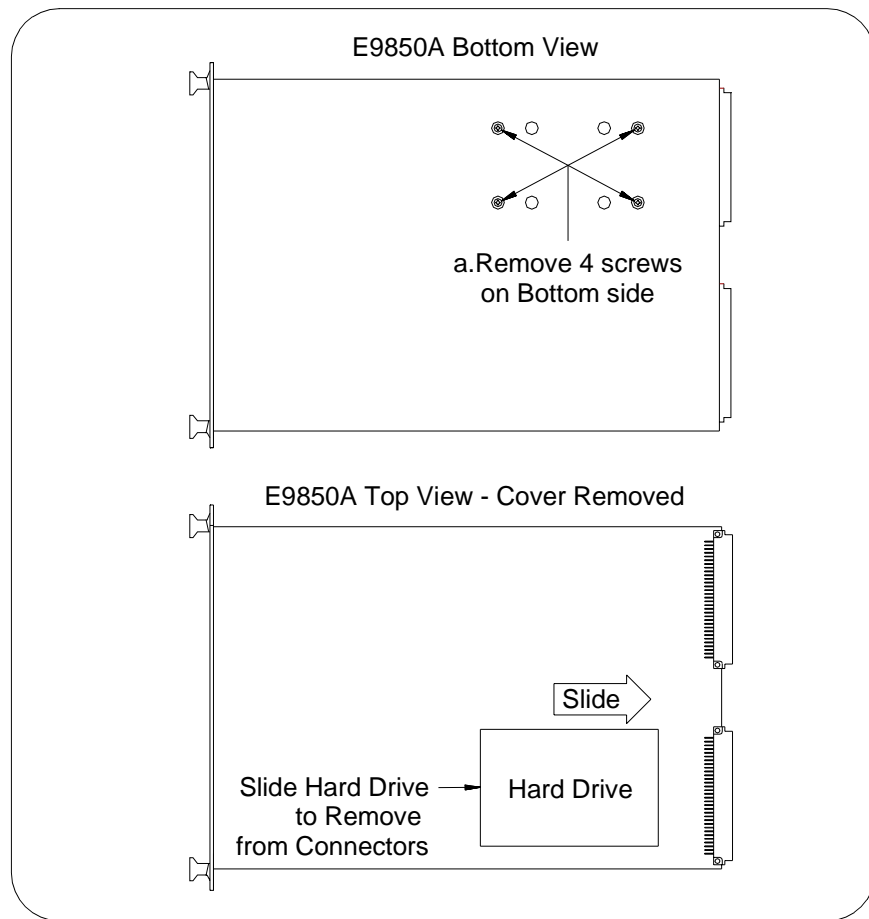

Figure 6-3. Removing the Hard Drive

Installing I/O Expansion Cards

This section gives guidelines to install one I/O expansion card (PCI or ISA) in the equivalent expansion slot in the E9850A. The E9850A includes one PCI and one ISA expansion slot.

E9850A Plug-In Boards Height

The E9850A can accommodate any standard-size PCI card and any XT-height ISA card. The height of an I/O card is measured from the bottom of the bus connector to the top of the board, as shown in Figure 6-4. Both XT-height ISA cards and PCI cards are 4.2 in. high. The E9850A does not support AT-height ISA cards, which are 4.8 in. high.

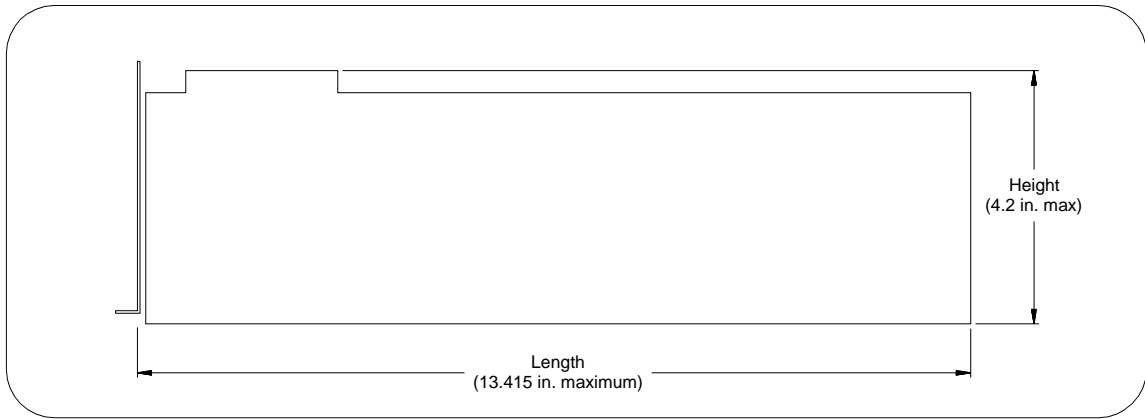

Figure 6-4. I/O Board Dimensions for E9850A Expansion Slot

Materials Needed

A user-designed front panel bracket is required for the I/O expansion card. The bracket should be manufactured from 0.03 in. [0.76 mm] thick 1010 cold-rolled steel. The finish should be 0.0003 in. [0.008 mm] nickel plate over 0.0001 in. [0.003 mm] copper flash.

Note

Contact Agilent Technologies (see *Appendix C - Customer Support*) for any questions about I/O expansion card panel bracket design.

Use a PEM nut or 4-40 nut with lock washer (hole diameter should be 0.125 in. [3.18 mm] and a 4-40 x 0.25 in. stainless steel panhead screw.

Installation Steps

1. Turn mainframe power OFF and remove the E9850A from the mainframe. Then, remove the E9850A cover (see Figure 6-2).
2. The E9850A includes a card guide that can be rotated to secure the top of a PCI or an ISA plug-in card, if the card is long enough to extend to the guide. Loosen the screw holding the guide and rotate the guide to the uppermost position for PCI cards or the lowermost position for ISA cards. See Figure 6-5.
3. For many PCI or ISA cards, you will need to modify the card faceplate to connect to your custom-designed bracket to be installed on the E9850A front panel. The first step is to manufacture the bracket.
4. For guidelines to build your custom-designed bracket, see Figure 6-6 for a front view of the PCI Board Expansion Bracket or Figure 6-7 for a front view of the ISA Board Expansion Bracket. In the drawings, dimensions are shown as inches [millimeters].

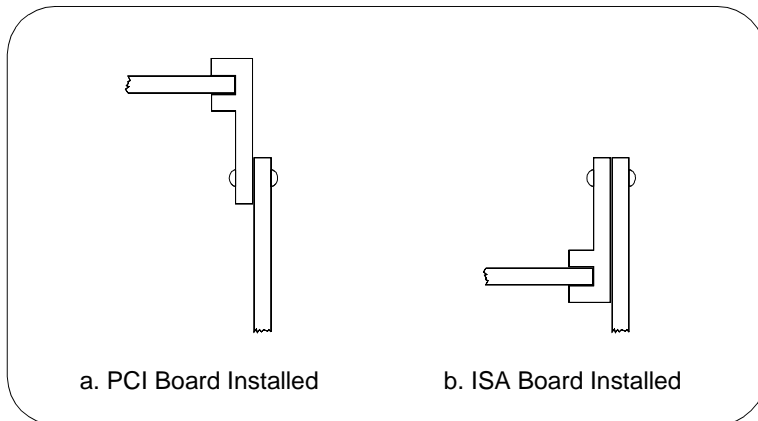

Figure 6-5. PCA and ISA Card Guide Positions

5. Remove the factory-installed front panel bracket and install your custom-designed bracket.
6. Modify the ISA or PCI card faceplate as required to fit to your custom-designed bracket. Then, seat the ISA or PCA card firmly in the appropriate (ISA or PCI) expansion bus connector.
7. Attach the card faceplate to your custom-designed bracket with two screws. You can use a PEM nut on the back (far) side of the bracket or a 4-40 nut with a lock washer (hole diameter should be 0.125 in.). In either case, use a 4-40 x 0.25 in. stainless steel panhead screw to mount the board/bracket assembly to the front panel.
8. Replace the E9850A cover and then replace the E9850A in the mainframe.

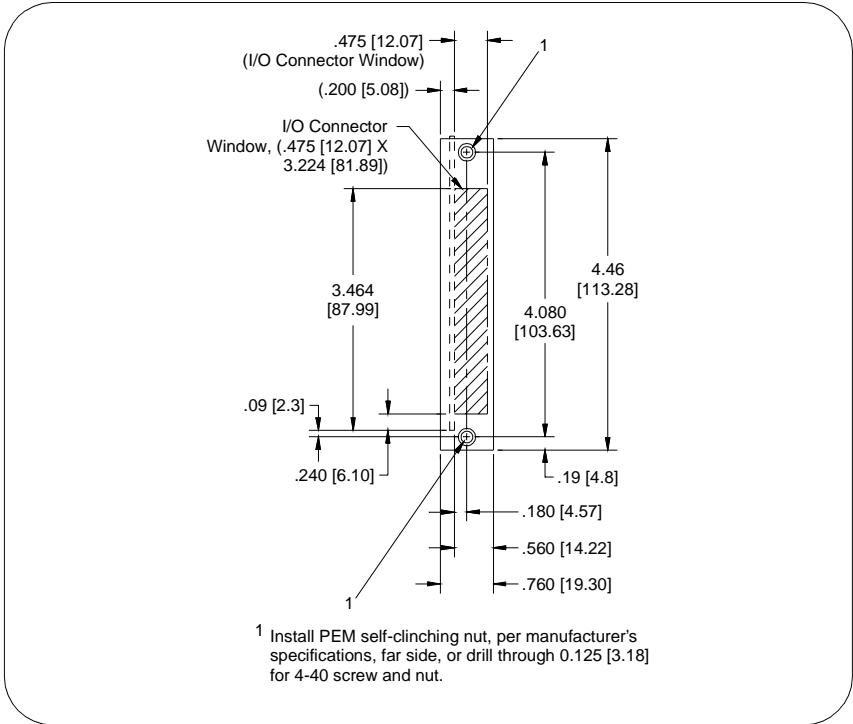

Figure 6-6. Front View of PCI Board Front Panel Bracket

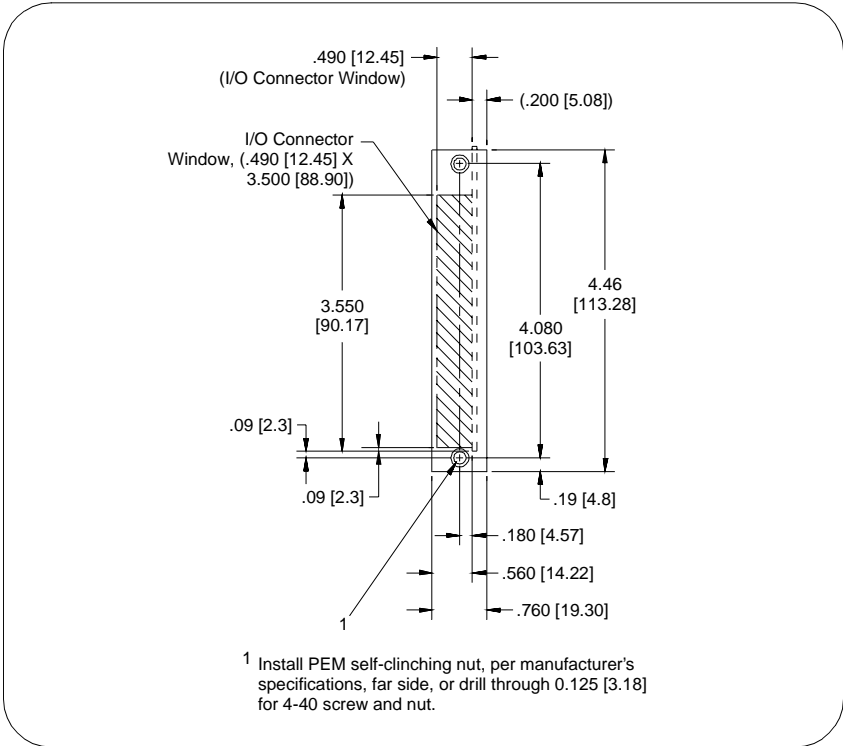

Figure 6-7. Front View of ISA Board Front Panel Bracket

Appendix A

E9850A Specifications

Appendix Overview

This appendix lists E9850A specifications, including:

- General VXI Specifications
- Physical
- Environmental
- Power Requirements
- Current Requirements
- VMEbus Capability Codes

General VXI Specifications

Category	Specifications
VXI Device Type	Embedded Controller
Data Transfer Bus	All per VXIbus Specification, Rev 1.4
Size	C-Size
Slots	2 Required
Connectors	P1/P2
Shared Memory	n/a
VXI Buses	Per VXIbus Spec, Rev 1.4
VXIbus Configuration Space	64 KB
A24 or A32 Space	Programmable (Minimum = 16 KB)

Physical

Category	Specifications
Dimensions	Fully enclosed, shielded VXI C-Size module. 233.35 x 340 mm (9.187 x 13.386 in.)
Weight	2.5 Kg (5.51 lb.) with 64 MB DRAM installed
VXI Keying Class	Class 1 TTL

Environmental

Area	Specification
Operating Location	Indoor: Sheltered location where air temperature and humidity are controlled within this product's specifications and the equipment is protected against direct exposure to climatic conditions such as direct sunlight, wind, rain, snow, sleet and icing, water spray or splash, hoarfrost, or dew (typically indoors). IEC 664 Pollution Degree 2.
Temperature	Operating: 0° C to +50° C Storage: -20° C to +70° C
Relative Humidity	Operating: 10% to 90% noncondensing Storage: 5% to 95% noncondensing
Cooling	Watt/slot: 24 Delta P (mm H ₂ O): 0.07 mm H ₂ O Air Flow (liter/s): 1.9 liters/second
EMI	FCC Class A and IEC 61326-1 verified
Random Vibration	Operational: 5 to 500 Hz, 0.3 g _{RMS} , 3 axes Non-operational: 5 to 500 Hz, 2.4 g _{RMS} , 3 axes
Functional Shock	MIL-T-28800E Class 3 (per Section 4.5.5.4.1). Half-sine shock pulse (11 ms duration, 30 g peaks, 3 shocks per face). Also meets IEC standard 60068-2-27.
Altitude	Up to 3,000 m

Current Requirements

+5 V is fused with a user-replaceable glass fuse, type 3AG, 15 A, slow blow. All other voltages use resettable-type circuit breakers that require no replacement by the user.

Voltage	Typical DC Current	Dynamic Current	Maximum Current
+5 V	9.0 A	4.0 A	15.0 A
-5.2 V	0.35 A	30 mA	2.0 A
-2 V	0.1 A	6 mA	2.0 A
+12 V	70 mA*	30 mA	2.0 A
-12 V	10 mA	10 mA	2.0 A
+24 V	1 mA	1 mA	-----
-24 V	1 mA	1 mA	-----

* = +12 V with oscilloscope and AM503, zeroed signal, DC, 10 mA/div, and oscilloscope also at 10 mA/div.

VMEbus Capability Codes

Code	Capability
A32, A24, A16 (master)	VMEbus master A32, A24, and A16 addressing
A32, A24, A16 (slave)	VMEbus slave A32, A24, and A16 addressing
D64, D32, D16, D08(EO) (master)	VMEbus master D64, D32, D16, and D08 data sizes
D64, D32, D16, D08(EO) (slave)	VMEbus slave D64, D32, D16, and D08 data sizes
BLT, MBLT (master)	VMEbus master block and D64 transfers
BLT, MBLT (slave)	VMEbus slave block and D64 transfers
RMW (master)	VMEbus master read/modify/write transfers
RMW (slave)	VMEbus slave read/modify/write transfers
RETRY (master)	VMEbus master retry support
RETRY (slave)	VMEbus slave retry support
FSD	First slot detector
SCON	VMEbus system controller (automatic detection)
PRI, RRS	Prioritized or round robin select arbiter
ROR, RWD, FAIR	Release on request, release when done, and FAIR bus requester
IH(7-1)	Interrupt handler for levels 7-1
I(7-1)	Interrupt requester for levels 7-1
D32, D16, D08(O) (Interrupt Handler)	VMEbus D32, D16, D08(O) interrupt handler
D32, D16, D08(O) (Interrupter)	VMEbus D32, D16, D08(O) interrupter
ROAK, RORA	Release on acknowledge or register access interrupter
BTO(x)	VMEbus bus timer (programmable limit)
LOCK	Can lock the VMEbus for indivisible transfers

Notes:

Appendix B

Frequently Asked Questions

What do the LEDs on the front of the E9850A mean?

See "LED Indicators" in *Chapter 4 - E9850A Description* for a description of the front panel LEDs.

Is something wrong if the red SYSF and FAIL LEDs stay lit after booting the E9850A?

If either the SYSF or FAIL LED remains lit, see "Troubleshooting Techniques" in *Chapter 6 - Servicing the E9850A* for troubleshooting steps.

Can I access 32-bit registers in my VXIbus system from the E9850A?

Yes. The E9850A uses the 32-bit PCI bus to interface to the VXIbus. The E9850A VXIbus circuitry also supports the VME64 standard for D64 accesses.

What kind of signal is CLK10 and what kind of signal do I need for an external CLK10?

CLK10 is a differential ECL signal on the backplane. However, because the oscillator and the EXT CLK input on the front panel use TTL levels, you need to supply a TTL-level signal for EXT CLK. The E9850A voltage converters convert the signal to differential ECL.

What is the accuracy of the CLK10 signal?

The CLKIO signal generated by the E9850A is ± 100 ppm (0.01%) as per the VXIbus specification. If you need a more accurate CLK10 signal, you can use the EXT CLK connector on the front panel.

What if my keyboard connector does not fit into the keyboard port?

You can plug keyboards that have a 6-pin PS/2 type connector directly into the E9850A. A keyboard adapter cable that ships with the E9850A adapts the larger AT keyboard connector to the 6-pin PS/2 connector.

What do I need to do if I want to install the E9850A in a slot other than Slots 0 and 1?

As factory-configured, the E9850A automatically detects if it is in Slot 0 of a VXIbus mainframe. You do not need to change jumper settings to install the device in a slot other than Slot 0 unless you have defeated the first slot detector (FSD) circuitry by changing the J12 jumper setting. See *Chapter 5 - E9850A Configuration* for details.

Note Devices in all other slots must not be configured as System Controller (Slot 0) devices. They must be configured either for Automatic System Controller Slot Detection or Non-System Controller operation.

How do I check the configuration of the memory, floppy drive, hard drive, time/date, etc.?

You can view these parameters in the BIOS setup. To enter the BIOS setup, reboot the E9850A and then press the <D> key during the memory tests. See "Using the BIOS Setup Program" in *Chapter 2 - Installing the E9850A* for more information.

How can I boot from an external SCSI hard drive?

In the BIOS setup change the boot sequence to SCSI. See "Using the BIOS Setup Program" in *Chapter 2 - Installing the E9850A*.

Can I use the internal IDE drive and an external SCSI hard drive at the same time?

Yes, you can select which device to boot from in the BIOS setup. See "Using the BIOS Setup Program" in *Chapter 2 - Installing the E9850A*.

My CMOS is corrupted. How do I set it back to default?

1. Enter the BIOS setup program. See "Using the BIOS Setup Program" in *Chapter 2 - Installing the E9850A* for details.
2. Select Optimal Defaults.
3. Select Save and Exit.

My operating system is damaged but my hard drive is OK. How can I reinstall the operating system?

Follow the instructions in c:\images\e985x.htm. (This file is also on the E9850A CD.)

What about running Resman?

Resman is the utility that performs the duties of a VXI Resource Manager as discussed in the VXIbus specification. When you set the E9850A to Logical Address 0, run Resman to configure your VXI instruments.

If your controller uses a different (nonzero) logical address and is a message-based device, start Resman before running it on the Logical Address 0 computer.

When do I need to run Resman?

Run Resman whenever you need to configure your VXI instruments. For example, if you power-cycle your VXI/VME chassis, your instruments will be reset and you will need to run Resman to configure them. Running Resman when the devices are not in a reset state may cause errors. If you run Resman again (after running it once), reset all VXI instruments.

You can perform resource manager operations from within T&M Explorer. Additionally, you can tell T&M Explorer to run Resman when the computer first boots. In this case, you may not need to run Resman again. If you configure the E9850A to run Resman at startup, Resman runs when power is applied to the mainframe. If you power-cycle the mainframe, the E9850A reboots, forcing Resman to run again.

How do I handle VME devices?

Although there is no way to detect VME devices in a system automatically, you can add them using the Add Device Wizard in T&M Explorer. With this procedure, you can reserve resources for each VME device and configure T&M Explorer to show VME devices along with other devices.

How do I determine NI-VXI/VISA software version I have installed?

1. From T&M Explorer, select About... from the Help menu. In the About dialog box, click the Software Info button to display version information on NI-VXI and NI-VISA files.
2. Under Windows NT, you can find version information by right-clicking any component and selecting the Properties option to display a property sheet with a version tab. This tab has version information about the product (NI-VXI) and the component (NIVXINT.DLL, for example).
3. You can find version information about the VISA driver through VISAIC by selecting About... from the Help menu.

How can I determine the serial number and hardware revision of the E9850A?

Run T&M Explorer and right-click the device at Logical Address 0 (LA: 0) under the VXI Frame 0 heading. Select Hardware Configuration, and T&M Explorer displays the dialog box for the E9850A. The title bar includes the serial number and hardware revision.

Which NI-VXI utility program must I use to configure the 9850A?

Use T&M Explorer to configure the E9850A. T&M Explorer is in the NIVXI program group folder.

Which NI-VXI utility program must I use to initialize the E9850A?

In Windows NT, the E9850A is automatically initialized at system startup.

Which NI-VXI utility program must I use to perform startup Resource Manager operations?

Use the Resman program (in the NIVXI directory) to perform startup Resource Manager operations. Resman uses the settings configured in T&M Explorer to initialize the VXIbus system and store the information to the RESMAN.TBL file (in the TBL subdirectory of the NIVXI directory). You can also run Resource Manager operations from T&M Explorer. Use T&M Explorer to configure Resman to run automatically at E9850A startup.

What can I do to make sure that my system is up and running?

The fastest method for testing the system is to run Resman. This program attempts to access memory in the upper A16 address space of each device in the system. If Resman does not report any problems, the VXI communication system is operational.

To test individual devices, you can use the VISAIC program to interactively issue NI-VXI functions or NL-VISA operations. You can use the VXlin () and VXlout () functions or the VXlinReg () and VXloutReg () functions to test register-based devices by programming their registers. If you have message-based devices, you can send and receive messages with the WSwrt () and WSrd () functions.

If you use Agilent VEE, National Instruments LabVIEW, or National Instruments LabWindows/CVI and you have instrument drivers for the devices in your mainframe, you can use the interactive features of these programs to test the functionality of the devices.

If You Have Questions

If you have any questions or require technical support from Agilent Technologies, you can contact us by telephone or via the World-Wide Web at the numbers/addresses shown. When you call or write us, please provide the following information:

- Your VXI system hardware configuration
- Your operating system (NT) and E9850A version
- The programming environment you are using
- A complete description of the problem
- A list of steps necessary to recreate the problem

Note So that we can most effectively help you solve the problem, please complete the *E9850A Configuration Form* for your E9850A configuration before you call or write Agilent Technologies.

Telephone Numbers

Americas Call Center: 1-800-452-4844
Canada Call Center: 1-877-894-4414
European Call Center: +31-20-547-9900
Japan Call Center: +81-426-56-7832

World-Wide Web

<http://www.agilent.com/find/contacts00> (two zeroes)

E9850A Configuration Form

You can copy and use this form to record hardware and software settings/revisions for your E9850A Embedded VXI Controller. You should complete a copy of this form when you first install your E9850A and each time you revise your hardware and/or software configuration. Completing this form before you contact Agilent Technologies for technical assistance will help us provide you more efficient service.

E9850A Hardware Settings and System Configuration	
Serial Number: _____	Installed in Mainframe: _____
Installed in Slots: _____	Hard Drive Size: _____
Processor Speed: _____	Video Memory: _____
CPU Bus Factor (W1, W3, W5, W7): _____	Bus Speed Setting (W4): _____
CMOS (W6): _____	Flash Protect (W8): _____
Ethernet Serial EEPROM Enable (W10): _____	SCSI Termination Enable (W11, W12): _____
Power Monitor (W15): _____	System Controller Slot Detection (J12): _____
MITE User/Factory Configuration (S1): _____	MITE Configuration Enable (S2): _____
Software Products	
Agilent VEE Version: _____	Agilent VISA Version: _____
Agilent SICL Version: _____	Agilent I/O Libraries Version: _____
NI-VXI/VISA Version: _____	Use Both NI-VXI and NI-VISA? _____
NI-488.8 Version (if applicable): _____	LabVIEW Version (if applicable): _____
LabWindows/CVI Version (if applicable): _____	Other Software Version: _____
Other Products	
Mainframe Make/Model: _____	Microprocessor: _____
Clock Frequency/Speed: _____	Total RAM Size: _____
Type of Video Board Installed: _____	Video Memory: _____
OS or Service Pack: _____	OS Mode: _____
Programming Language/Version: _____	Monitor (Mfg, Model): _____
Mouse (Mfr, Model): _____	Keyboard (Mfg, Model): _____

(continued on next page)

SCSI Devices/IDs			
ID	Manufacturer	Description	Function

AT/PCI Plug-in Boards		
Manufacturer	Description	Function

Other Instruments Installed in VXI Mainframe				
Slot	LA	DMA	IRQ	Manufacturer, Description, Function

Notes:

Appendix D

Porting Considerations

Introduction

This appendix describes some considerations when porting from the E623xA family of Embedded Pentium Controllers to the E9850A VXI Embedded Pentium Controller. Porting considerations from the E623xA family to the E9850A center around three major categories:

- Default SICL interface name changes
- Resource Manager differences
- VISA and SICL issues

Default SICL Interface Name Changes

The default SICL interface names defined on the E9850A Embedded Pentium Controller (gpib0 and vxi0) differ from the default names used on E623xA Embedded Pentium Controllers. You can change these names to the previous defaults of hpib7 and vxi by running the I/O Config configuration utility and editing the appropriate configured interface.

Resource Manager Differences

The resource manager and associated configuration tools used in E623xA Embedded Pentium Controllers and E9850A Embedded Pentium Controllers are very different. The E623xA Embedded Pentium Controllers use SURM and the VXI Configuration utilities, while the E9850A Embedded Pentium Controller uses National Instruments' Resman and T&M Explorer.

Although the general function of these tools is similar, major differences in implementation may affect how the VXI system is configured, particularly in the areas of A24/A32 memory allocation and VXI IRQ line allocation. Depending on your system configuration, you may also need to modify the PCI User Window size, which controls how much VXI A24/A32 memory may be simultaneously mapped.

A24/A32 Memory Allocation

Resman may allocate different A24 and A32 memory addresses to VXI cards than SURM. Programs that expect specific absolute VXI A24 or A32 addresses for the VXI cards must be modified.

Programs that use the SICL `imap(id, I_MAP_EXTEND, ...)` or VISA `viMapAddress()` calls on VXI devices will run unmodified. Programs that use the SICL `imap(id, I_MAP_A24, ...)` or related calls or that use the VISA MEMACC resource may need modification.

VXI IRQ Line Allocation

VXI IRQ line allocation affects VXI systems with multiple VXI devices that can handle VXI interrupts. Examples of VXI devices that are interrupt handlers are the Agilent E1485A DSP module and E1562x family of VXI data disks.

By default, SURM assigns VXI IRQ line 1 to the E623xA to handle, then allocates the other VXI IRQ lines to other VXI cards. Resman, however, assigns IRQ line 7 to the E9850A Embedded Pentium Controller and the other IRQ lines to other cards.

If your VXI system has multiple VXI handlers, this results in VXI interrupts being handled by the wrong VXI device. The most likely result is that programs will hang. (Most Agilent Technologies VXI cards are set to IRQ 1 at the factory.)

To compensate for this difference, run T&M Explorer and explicitly assign interrupt lines to each handler. To do this:

1. Right-click the VXIpc-870 device in the T&M Explorer - System View window.
2. Select Hardware Configuration and then select the Device tab.
3. Change the setting for System Interrupt Level to 1 and Number of Handlers to 1. Then, click OK.
4. Right-click the VXI Frame 0 device and select Properties and then select the Interrupt Handlers tab.
5. For each IRQ line you want to assign to a specific handler, click on that IRQ line and then click Edit.
6. Check the circle next to Assign to device at logical address, enter the logical address of the handling device and then click OK.
7. Click OK on the VXI Frame 0 box and then exit T&M Explorer.
8. Rerun Resman to configure the VXI system for the new settings.

Note Alternately, you can change the IRQ settings for all VXI cards in the system to match the IRQ assignments made by Resman.

PCI User Window

For systems that require a large amount of VXI A24 or A32 memory to be mapped simultaneously, you may need to modify this parameter. To do this, run T&M Explorer. In the T&M Explorer - System View window, right-click the device at logical address 0, select the PCI tab, enter the new value, and then click OK. You should enter a value equal to or greater than the total amount of VXI A24 and A32 space that you will simultaneously map in all programs.

SICL/VISA Differences

The E623xA Embedded Pentium Controllers use the Hewlett-Packard/Agilent Technologies version of SICL and VISA. The E9850A Embedded Pentium Controller uses Agilent SICL and National Instruments VISA. Only very minor implementation differences exist with VISA.

For the E9850A Embedded Pentium Controller, SICL communicates with the controller's VXI and GPIB hardware using NI-VXI and NI-488.2 through a translation layer. Due to hardware constraints and differences between the SICL architecture and the architecture of the underlying National Instruments drivers, it is not possible to perfectly map all SICL-specified functionality. The resulting SICL considerations follow.

Mixing SICL and VISA

1. Mixing SICL and VISA calls in the same process is not supported.
2. Using SICL and VISA calls in separate processes must be done carefully. SICL and VISA locking use different mechanisms so that a SICL lock in one process will not prevent VISA in another process from accessing a device or interface and vice versa.

SICL on NI-VXI

1. Termination reasons on `iread()` are sometimes incomplete. If `I_TERM_CHR` is detected, `I_TERM_END` is not returned even if it is true.
2. If two processes have enabled interrupts on an interface session and an interrupt occurs, only one process will receive the interrupt.
3. Stopping a process that is waiting in a hung `iwrite()` call causes all subsequent VXI I/O to fail until the VXI Resource Manager is rerun.
4. Timeouts do not always behave as expected. Underlying NI-VXI calls are serialized. That is, a call in progress will complete before another call can start. The timeout timer for the second call is not started until the first call returns. This means that the second call may succeed when it was expected to timeout.

5. The VXI resource manager is not run programmatically when an interface `iclear()` is issued. If an interface `iclear()` is issued, `SYSRESET` is asserted on the VXI backplane. This causes all VXI devices in the mainframe to reset. Resman must be run manually before attempting further VXI operations.

Note The E985x can be configured to reboot on `SYSRESET`. The default is not to reboot. This is the same behavior as on the E623xA Embedded Pentium Controllers, but is included for completeness.

6. VXI trigger information:
 - a. Supported triggers are `I_TRIG_TTL0-7`, `I_TRIG_ECL0-1` and `I_TRIG_EXT0`.
 - b. When `I_TRIG_EXT0` is used as an input, it maps to the front panel Trig In connector.
 - c. When `I_TRIG_EXT0` is used as an output, it maps to the front panel Trig Out connector.
 - d. `I_TRIG_EXT0` cannot be asserted (`ivxitrigon / ivxitrigoff`), its state cannot be determined with `ivxibusstatus`, and it cannot be enabled to interrupt. Route other trigger lines to/from `I_TRIG_EXT0` if you need to assert, check status, or interrupt with `I_TRIG_EXT0`.
7. SICL should not write to arbitrary locations in the E985x VXI shared memory. The controller's VXI shared memory maps areas that are not safe to access. Safe access is provided in VISA by the `viMemAlloc()` function.

SICL does not provide a similar mechanism, so writing to arbitrary locations in the controller's shared memory area may damage important data structures stored in that area and subsequently cause unexpected behavior.

Note This is the same behavior as for the E623xA Embedded Pentium Controllers, but is included for completeness.

SICL on NI GPIB (NI-488.2)

1. `ilock()` on an interface session will block an `iopen()` in another process on the same interface or on any devices on that interface. If an `iopen()` is attempted on a locked interface, the `iopen()` will timeout if the interface is not unlocked before the timeout period. The default timeout is 10 seconds.

This can be changed by manually editing the registry value of the `lopenTimeout` key. (See the following for more information about manually editing registry values.) A possible workaround is to have all processes do their `iopen()`'s before any process attempts to lock.

2. If SRQ is asserted and then removed while an `iread()` or `iwrite()` call is in progress, that SRQ will not be detected.

Note

Most instruments that can assert SRQ will leave SRQ asserted until an `ireadstb()` is performed and the underlying reason for the SRQ is handled, so this should not be an issue for most SICL users.

3. If an attempt is made to use `iopen()` on more than 100 different devices in a process, an `I_ERR_OS` will be returned, even if some of the devices are closed before opening others.
4. A device `iopen()` in one process will unaddress the bus and can interfere with another process that is doing I/O on an interface session using `igpibsendcmd()` followed by `iread()` or `iwrite()`. The workaround for this problem is to use `ilock()` around the `igpibsendcmd()` / `iread()` or `iwrite()` calls to prevent another process from changing the addressed state of the bus between these calls.
5. Timeouts do not always work as expected. Underlying NI-488.2 calls are serialized. That is, a call in progress will complete before another call can start. Also, the underlying NI-488.2 library performs timeout timing not SICL. This has two implications:
 - a. NI-488.2 has a few discrete timeouts so the actual timeout value, while never shorter than the specified time, can be considerably longer.
 - b. The timeout timer for a SICL call does not start until the underlying NI-488 call is made.

Thus, a SICL call that is waiting for another SICL call to complete may not timeout as expected because it is waiting in SICL where the timeout timer is not running.

6. It is possible to miss transient interrupts. The underlying NI-488.2 architecture requires a polling scheme for interrupts. By default, this polling is done every 30 ms. If an interrupt condition does not last at least 30 ms, it is possible the interrupt will be missed.

The default value for `lopenTimeout` is 10000 ms and the default value for `IrqLoopDelay` is 30 ms. The polling rate can be changed by manually editing the registry value of `IrqLoopDelay` for the interface. (See the following for more information about manually editing registry values.) Shorter `IrqLoopDelay` times will reduce interrupt response latency but use more CPU bandwidth.

7. If you decide to edit the `lopenTimeout` or `IrqLoopDelay` parameters in the registry manually, be aware of the following caution.



Caution

Making mistakes when manually editing the registry can make Windows NT unstable and possibly prevent the controller from booting. Use caution when attempting to edit the registry manually.

To edit the registry manually:

- a. In the Start | Run box type `regedit` and then click OK.
- b. Navigate to `HKEY_LOCAL_MACHINE\Agilent\IO Libraries\CurrentVersion`. Look at the `INTFn` keys to find the interface you want to edit.
- c. Click the `INTFn` key you want. In the right pane, right-click the key you want to change (`lopenTimeout` or `IrqLoopDelay`) and select `Modify`. Enter the value you want (the number is in units of milliseconds) and click OK.

Appendix E

Connector Descriptions

Appendix Overview

This appendix describes front and rear panel connectors for the E9850A Embedded VXI Controller connectors. Appendix contents are:

- SVGA Connector 78
- Keyboard/Mouse Connectors 79
- Universal Serial Bus (USB) Connector 80
- Speaker Connection 81

- COM1 and COM2 Connectors 82
- Parallel Port Connector 83
- SCSI Connector. 85
- Ethernet Connector 87

- GPIB (IEEE-488.2) Connector 88
- External SMB Connectors 90
- Rear Panel (P1 and P2) Connectors 91

Note The illustrations in this appendix show the mating face of the connectors. An asterisk (*) after a signal name indicates the signal is active low. Signal characteristics are listed for the SMB and Speaker Connections. See the relevant standard for the characteristics for SVGA, SCSI, Ethernet, keyboard, mouse, parallel, serial, and GPIB connectors.

SVGA Connector

Figure E-1 shows location and pinouts for the SVGA connector. See Table E-1 for the name and description of the SVGA connector signals.

Note Amp manufactures a mating connector with part numbers 748364-1 (housing) and 748333-2 (pin contact).

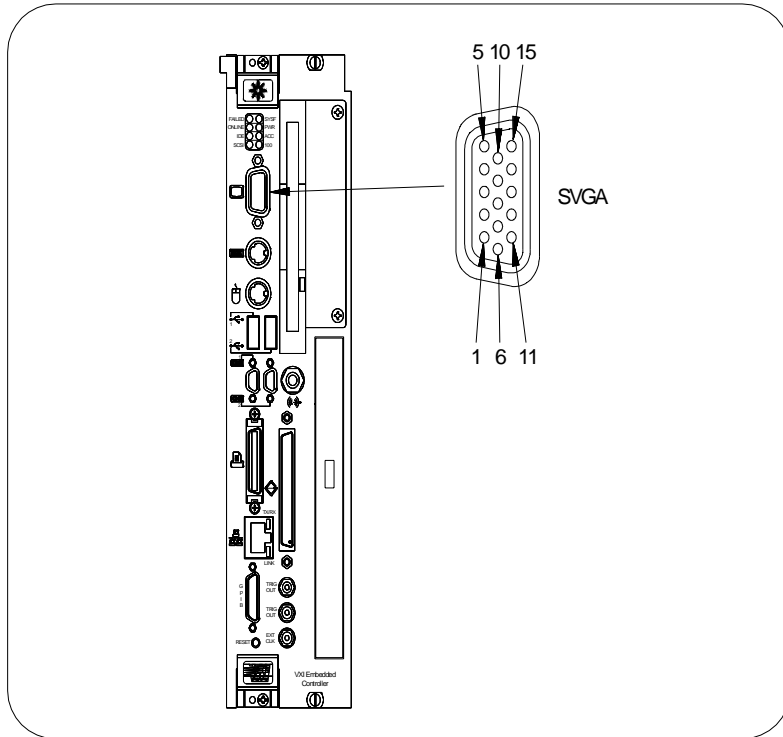

Figure E-1. SVGA Connector Location and Pinout

Table E-1. SVGA Connector Signals

Pin	Signal Name	Signal Description	Pin	Signal Name	Signal Description
1	R	Red	9	NC	Not Connected
2	G	Green	10	GND	Ground
3	B	Blue	11	NC	Not Connected
4	NC	Not Connected	12	SD	Serial Data
5	GND	Ground	13	HSync	Horizontal Sync
6	GND	Ground	14	VSynC	Vertical Sync
7	GND	Ground	15	SC	Serial Clock
8	GND	Ground			

Keyboard/Mouse Connectors

Figure E-2 shows location and pinouts for the keyboard and mouse connectors. See Table E-2 for the name and description of the keyboard and mouse connector signals.

Note Amp manufactures a mating connector with part numbers 212437-4 (housing), 212435-7 (ferrule), and 66735-4 (pin contact).

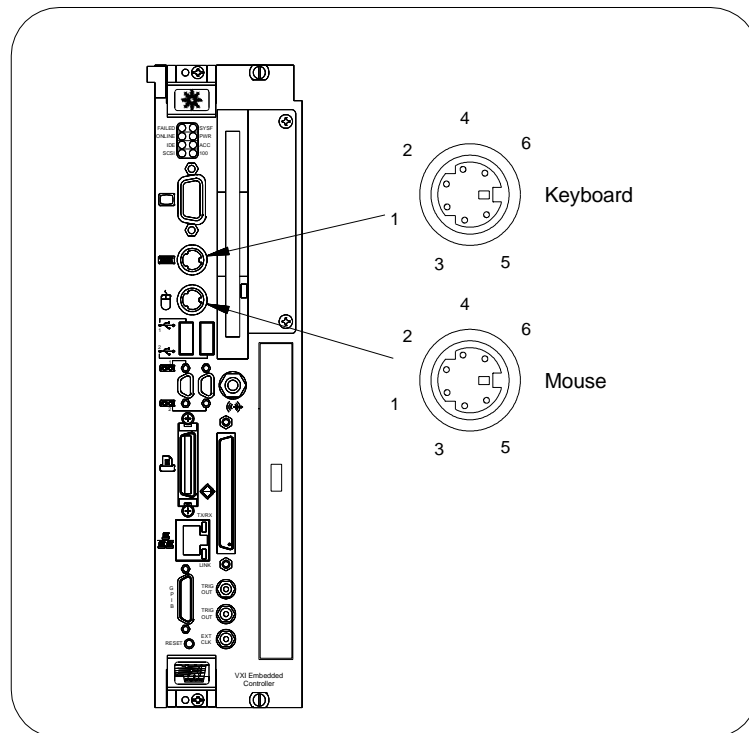

Figure E-2. Keyboard and Mouse Connectors Location and Pinout

Table E-2. Keyboard and Mouse Connector Signals

Pin	Signal Name	Signal Description
1	DATA	Data
2	NC	Not Connected
3	GND	Ground
4	+5V	+5
5	CLK	Clock
6	NC	Not Connected

Universal Serial Bus (USB) Connector

Figure E-3 shows location and pinouts for the Universal Serial Bus (USB) connector. See Table E-3 for the name and description of the USB connector signals.

Note Amp manufactures a mating connector, part number 787633.

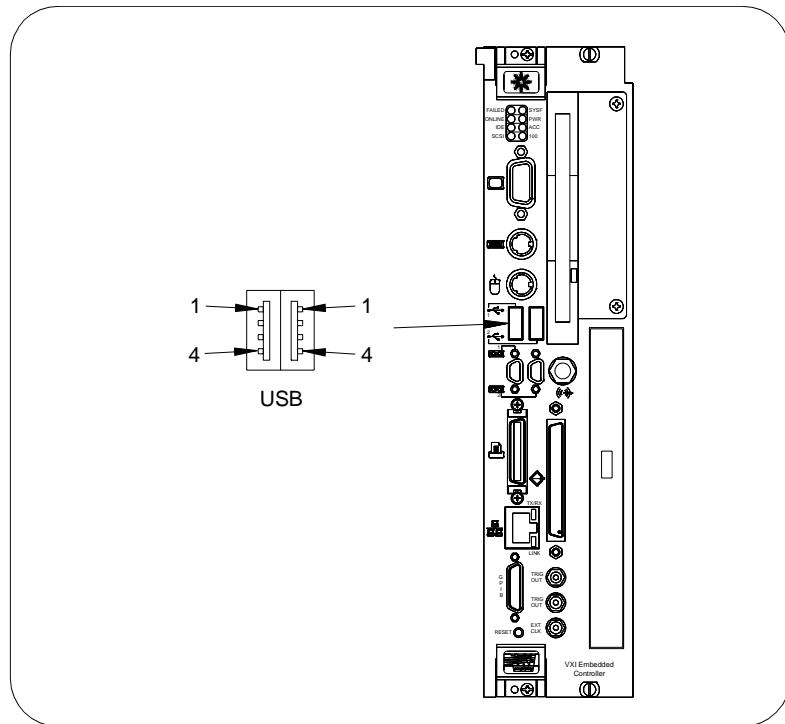

Figure E-3. USB Connectors Layout and Pinouts

Table E-3. USB Connector Signals

Pin	Signal Name	Signal Description
1	VCC	Cable Power (+5 V)
2	-Data	USB Data-
3	+Data	USB Data+
4	GND	Ground

Speaker Connection

Figure E-4 shows location and pinouts for the speaker connection. See Table E-4 for the signal characteristics of the speaker connection.

Note Switchcraft manufactures a mating speaker connector, part number 750.

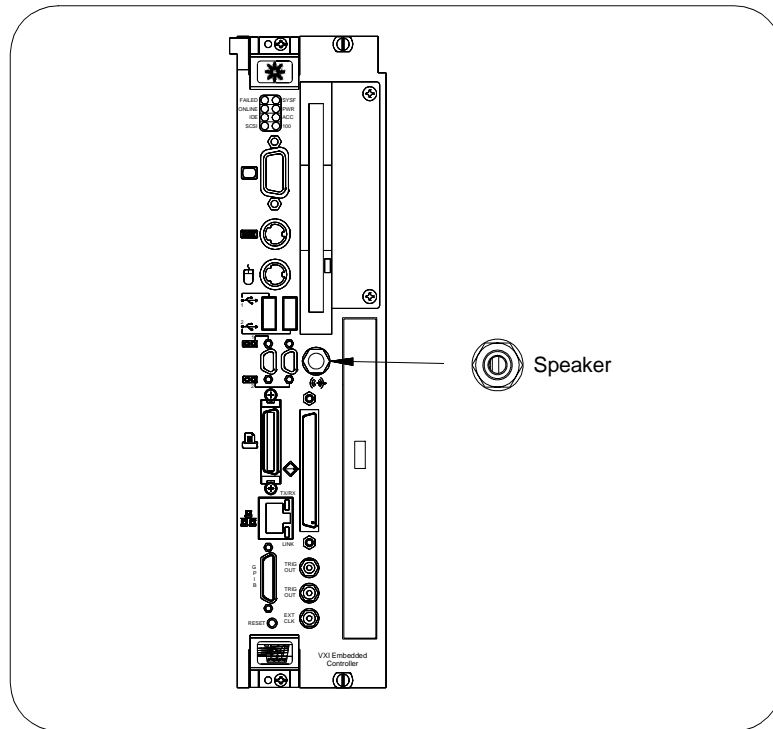

Figure E-4. Speaker Connection Location

Table E-4. Speaker Connection Signal Characteristics

Signal	Voltage Range	Maximum Current	Frequency Range
Speaker	0 to 4.3 V	75 mA	DC - 20 kHz

COM1 and COM2 Connectors

Figure E-5 shows location and pinouts for the COM1 and COM2 connectors. See Table E-5 for the name and description of the COM1 and COM2 connector signals.

Note ITT Cannon manufactures a serial port mating connector, part number MDSM-9SC-Z11, for the COM1 and COM2 connectors.

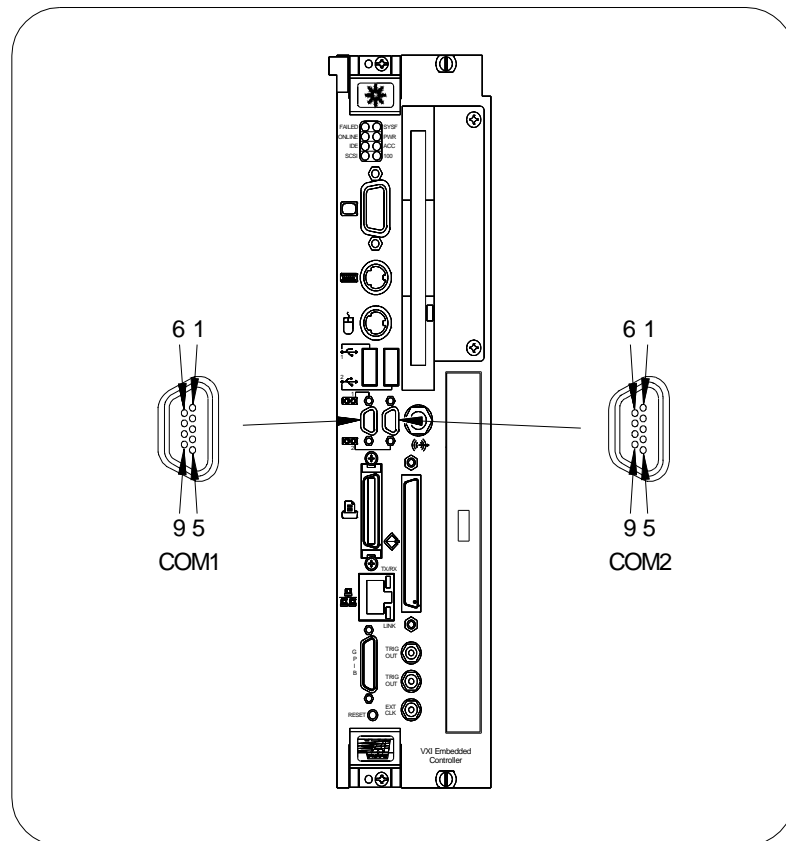

Figure E-5. COM1 and COM2 Connectors Location and Pinouts

Table E-5. COM1 and COM2 Connector Signals

Pin	Signal Name	Signal Description	Pin	Signal Name	Signal Description
1	DCD*	Data Carrier Detect	6	DSR*	Data Set Ready
2	RXD*	Receive Data	7	RTS*	Ready to Send
3	TXD*	Transmit Data	8	CTS*	Clear to Send
4	DTR*	Data Terminal Ready	9	RI*	Ring Indicator
5	GND	Ground			

Parallel Port Connector

Figure E-6 shows location and pinouts for the IEEE 1284 (Parallel Port) connector. See Table E-6 for the name and description of the Parallel Port connector signals.

Note Amp manufactures a parallel port compatible connector, part number 2-175677-5.

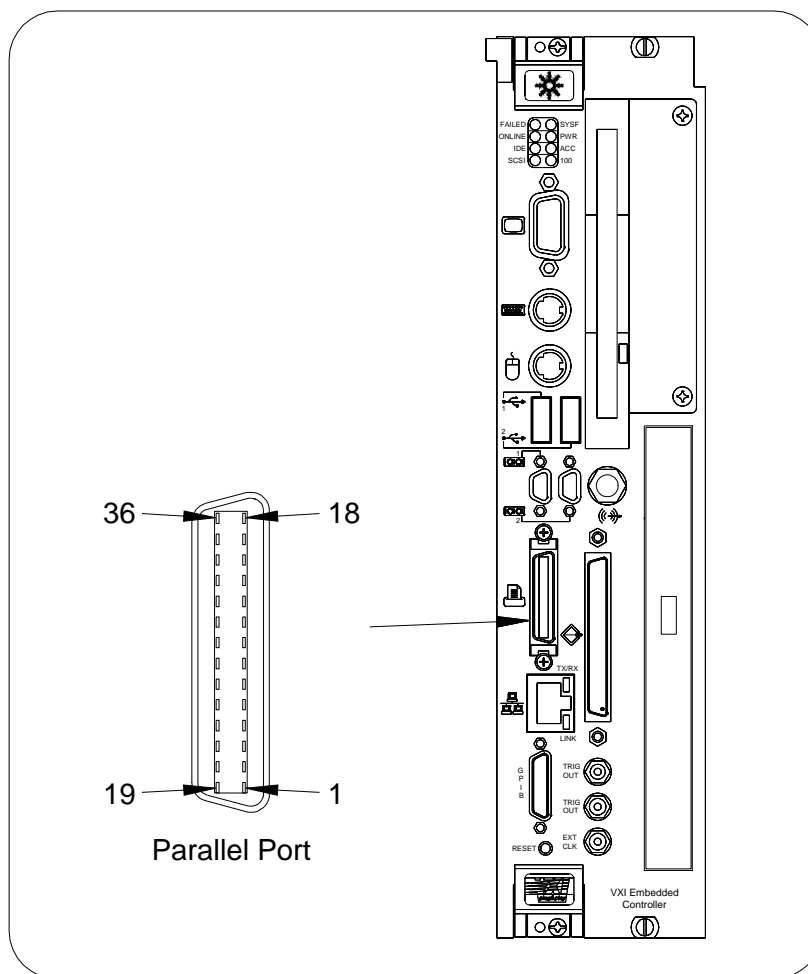

Figure E-6. Parallel Port Connector Location and Pinouts

Table E-6. Parallel Port Connector Signals

Pin	Signal Name	Signal Description
1	BUSY*	Device Busy
2	SLCTIN*	Select Input
3	ACK*	Acknowledge
4	FAULT*	Fault
5	ERROR	Error
6	PD0	Data Bit 0
7	PD1	Data Bit 1
8	PD2	Data Bit 2
9	PD3	Data Bit 3
10	PD4	Data Bit 4
11	PD5	Data Bit 5
12	PD6	Data Bit 6
13	PD7	Data Bit 7
14	INIT*	Initialize Printer
15	STROBE*	Strobe
16	SLCT	Select
17	AUTOFD	Auto Line Feed
18	+5V	+5 V
19-35	GND	Ground
36	NC	Not Connected

SCSI Connector

Figure E-7 shows location and pinouts for the Ultra Wide SCSI connector. See Table E-7 for the name and description of the SCSI connector signals.

Note Amp manufactures a SCSI-compatible connector, part number 749111-6, with shielded enclosure 750752-1.

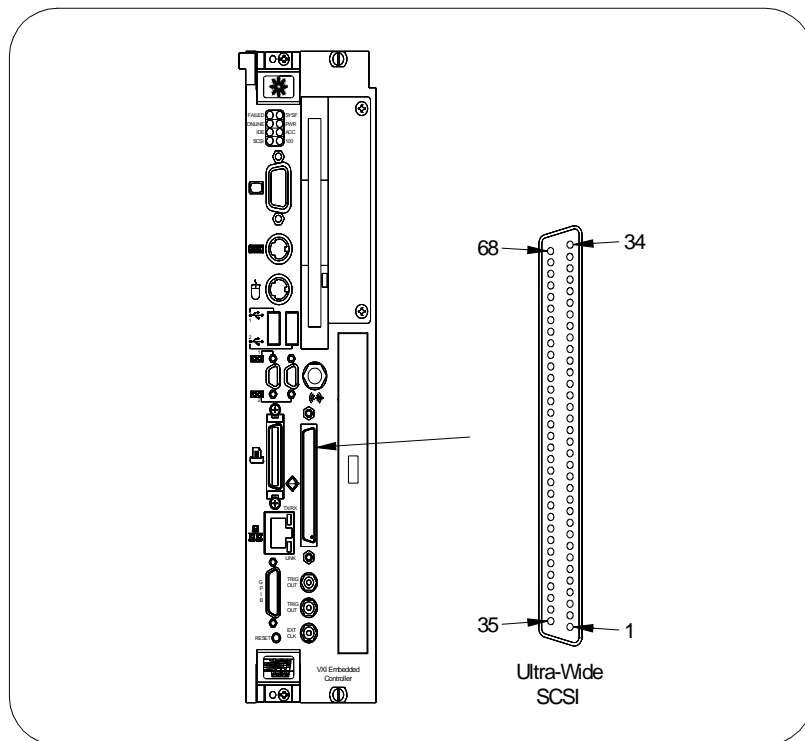

Figure E-7. SCSI Connector Location and Pinouts

Table E-7. SCSI Connector (Single-Ended) Signals

Conn-ector**	SCSI Signal	Conn-ector**	SCSI Signal	Conn-ector**	SCSI Signal	Conn-ector*	SCSI Signal
1	GND	18	TERMPWR	35	DB(12)*	52	TERMPWR
2	GND	19	RSRVD	36	DB(13)*	53	RSRVD
3	GND	20	GND	37	DB(14)*	54	GND
4	GND	21	GND	38	DB(15)*	55	ATN*
5	GND	22	GND	39	DP1	56	GND
6	GND	23	GND	40	DB(0)*	57	BSY*
7	GND	24	GND	41	DB(1)*	58	ACK*
8	GND	25	GND	42	DB(2)*	59	RST*

Table E-7. SCSI Connector (Single-Ended) Signals

Conn-ector**	SCSI Signal	Conn-ector**	SCSI Signal	Conn-ector**	SCSI Signal	Conn-ector*	SCSI Signal
9	GND	26	GND	43	DB(3)*	60	MSG*
10	GND	27	GND	44	DB(4)*	61	SEL*
11	GND	28	GND	45	DB(5)*	62	C/D*
12	GND	29	GND	46	DB(6)*	63	REQ*
13	GND	30	GND	47	DB(7)*	64	I/O*
14	GND	31	GND	48	DP0	65	DB(8)*
15	GND	32	GND	49	GND	66	DB(9)*
16	GND	33	GND	50	GND	67	DB(10)*
17	TERMPWR	34	GND	51	TERMPWR	68	DB(11)*

**16-Bit Wide SCSI-3 "P" (Primary) Connector Pinout (Single-Ended for High-Density 68-Pin Connector)

Ethernet Connector

Figure E-8 shows location and pinouts for the Ethernet connector. See Table E-8 for the name and description of the Ethernet connector signals.

Note Amp manufactures a mating connector, part number 554739-1.

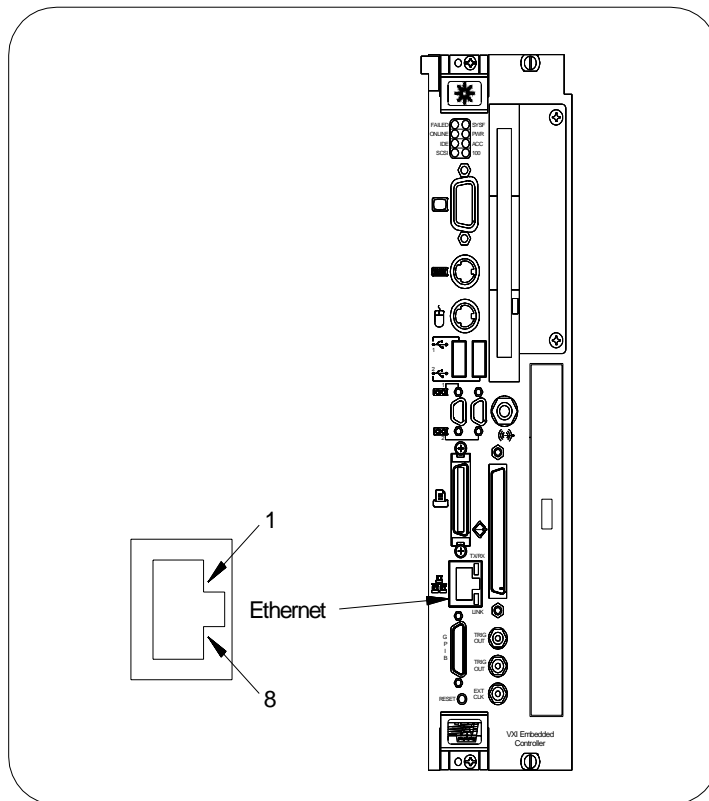

Figure E-8. Ethernet Connector Location and Pinout

Table E-8. Ethernet Connector Signals

Pin	Signal Description	Pin	Signal Description
1	Differential Transmit +	5	Not Connected
2	Differential Transmit -	6	Differential Receive -
3	Differential Receive +	7	Not Connected
4	Not Connected	8	Not Connected

GPIB (IEEE 488.2) Connector

Figure E-9 shows location and pinouts for the GPIB (IEEE 488.2) connector. See Table E-9 for the name and description of the GPIB (IEEE 488.2) connector signals.

Note ITT Cannon manufactures a GPIB mating connector, part number MDSM-255C-Z11.

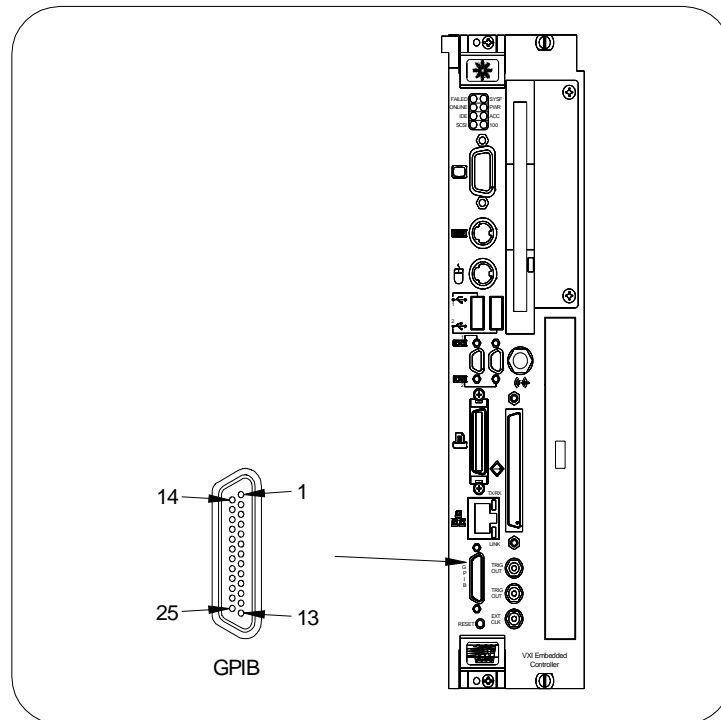

Figure E-9. GPIB Connector Location and Pinouts

Table E-9. GPIB Connector Signals

Pin	Signal Name	Signal Description
1	DI01*	Data Bit 1
2	DI02*	Data Bit 2
3	DI03*	Data Bit 3
4	DI04*	Data Bit 4
5	EOI*	End or Identify
6	DAV*	Data Valid
7	NRFD*	Not Ready for Data

Table E-9. GPIB Connector Signals

Pin	Signal Name	Signal Description
8	NDAC*	Not Data Accepted
9	IFC*	Interface Clear
10	SRQ*	Service Request
11	ATN*	Attention
12	SHIELD	Chassis Ground
13	DI05*	Data Bit 5
14	DI06*	Data Bit 6
15	DI07*	Data Bit 7
16	DI08*	Data Bit 8
17	REN*	Remote Enable
18-25	GND	Logic Ground

External SMB Connectors

The SMB connectors are used for an external clock signal and TTL trigger input and output. Figure E-10 shows location and pinouts for the External SMB connectors. See Table E-10 for the name and description of the External SMB connector signals. See Table E-11 for the signal characteristics for the SMB connections.

Note Amp manufactures an SMB mating connector, part number 1-413985-0.

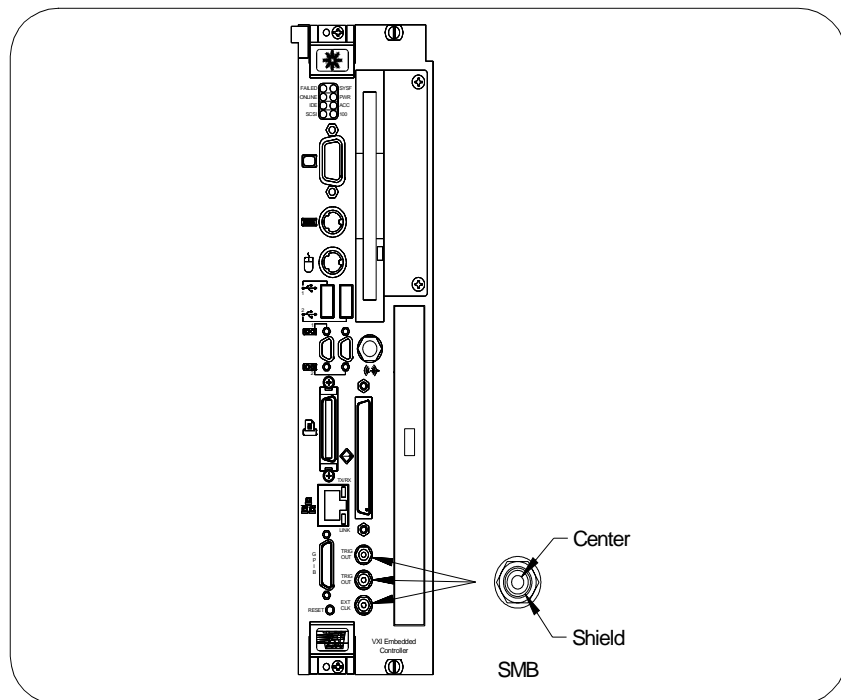

Figure E-10. SMB Connectors Location and Pinout

Table E-10. SMB Connector Signals

Pin	Signal Description
Center	TTL Trigger or Clock Signal
Shield	Ground

Table E-11. SMB Connectors Signal Characteristics

Signal	Voltage Range	Maximum Current	Frequency Range
TRIG Out, CLK Out	0 to 3.4 V	200 mA	DC - 10 MHz
TRIG In, Clk In	0 to 5 V	100 mA ¹	DC - 10 MHz

¹ With 50 Ω termination

Rear Panel (P1 and P2) Connectors

Figure E-11 shows location and pinouts for the VXIbus P1 and P2 connectors on the E9850A rear panel. See Table E-12 for the name and description of the VXIbus P1 connector signals. See Table E-13 for the name and description of the VXIbus P2 connector signals.

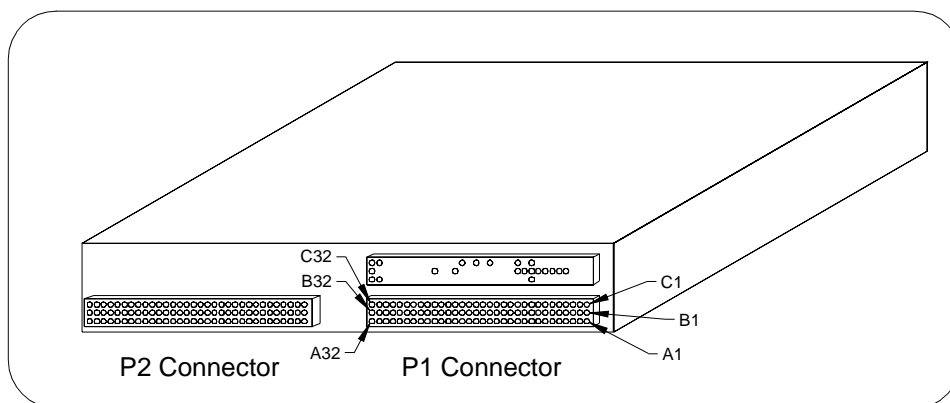

Figure E-11. VXIbus P1 and P2 Connectors Location and Pinouts

Table E-12. VXIbus P1 Connector Signals

Pin	Row C	Row B	Row A	Pin	Row C	Row B	Row A
1	D08	BBSY*	D00	17	A21	AM1	GND
2	D09	BCLR*	D01	18	A20	AM2	AS*
3	D10	ACFAIL*	D02	19	A19	AM3	GND
4	D11	BG0IN*	D03	20	A18	GND	IACK*
5	D12	BG0OUT*	D04	21	A17	Not Conn.	IACKIN*
6	D13	BG1IN*	D05	22	A16	Not Conn.	IACKOUT*
7	D14	BG1OUT*	D06	23	A15	GND	AM4
8	D15	BG2IN*	D07	24	A14	IRQ7*	A07
9	GND	BG2OUT*	GND	25	A13	IRQ6*	A06
10	SYSFAIL*	BG3IN*	SYSCLK	26	A12	IRQ5	A05
11	BERR*	BG3OUT*	GND	27	A11	IRQ4	A04
12	SYSRESET*	BR0*	DS1*	28	A10	IRQ3	A03
13	LWORD*	BR1*	DS0*	29	A09	IRQ2	A02
14	AM5	BR2*	WRITE*	30	A08	IRQ1	A01
15	A23	BR3*	GND	31	+12V	Not Conn.	-12V
16	A22	AM0	DTACK*	32	+5V	+5V	+5V

Table E-13. VXIbus P2 Connector Signals

Pin	Row C	Row B	Row A	Pin	Row C	Row B	Row A
1	CLK10+	+5V	ECLTRG0	17	Not Conn.	D19	MODID04
2	CLK10-	GND	-2V	18	Not Conn.	D20	MODID03
3	GND	Not Conn.	ECLTRG1	19	-5.2V	D21	-5.2V
4	-5.2V	A24	GND	20	Not Conn.	D22	MODID02
5	Not Conn.	A25	MODID12	21	Not Conn.	D23	MODID01
6	Not Conn.	A26	MODID11	22	GND	GND	GND
7	GND	A27	-5.2V	23	TTLTRG1*	D24	TTLTRG0*
8	Not Conn.	A28	MODID10	24	TTLTRG3*	D25	TTLTRG2*
9	Not Conn.	A29	MODID09	25	GND	D26	+5V
10	GND	A30	GND	26	TTLTRG5*	D27	TTLTRG4*
11	Not Conn.	A31	MODID08	27	TTLTRG7*	D28	TTLTRG6*
12	Not Conn.	GND	MODID07	28	GND	D29	GND
13	-2V	+5V	-5.2V	29	Not Conn.	D30	Not Conn.
14	Not Conn.	D16	MODID06	30	GND	D31	MODID00
15	Not Conn.	D17	MODID05	31	Not Conn.	GND	GND
16	GND	D18	GND	32	Not Conn.	+5V	Not Conn.

Glossary

Prefix	Meaning	Value
p-	pico-	10^{-12}
n-	nano-	10^{-9}
μ	micro-	10^{-6}
m-	milli-	10^{-3}
k-	kilo-	10^3
M-	mega-	10^6
G-	giga-	10^9
t-	tera-	10^{12}

Symbols

$^{\circ}$ degrees
 Ω ohms

A

A	Amperes
A24 space	VXIbus address space equivalent to the VME 16 MB standard address space.
A32 space	VXIbus address space equivalent to the VME 4 GB extended address space.
address	Character code that identifies a specific location (or series of locations) in memory.
address space	A set of 2^n memory locations differentiated from other such sets in VXI/VMEbus systems by six addressing lines known as address modifiers. n is the number of address lines required to uniquely specify a byte location in a given space. Valid numbers for n are 16, 24, and 32. In VME/VXI, since there are six address modifiers there are 64 possible address spaces.
ANSI	American National Standards Institute
API	Application Programming Interface. The direct interface an end user sees when creating an application.
ASD	Acceleration Spectral Density. A calculation of random vibration intensity across a frequency bandwidth.

ASIC	Application-specific integrated circuit. A proprietary semiconductor component designed and manufactured to perform a set of specific functions for a specific customer.
B	
b	Bit. One binary digit, either 0 or 1.
B	Byte. Eight related bits of data, an 8-bit binary number. Also used to denote the amount of memory required to store one byte of data.
backplane	An assembly (typically a printed circuit board) with 96-pin connectors and signal paths that bus the connector pins. A C-size VXIbus system has two sets of bus connectors called J1 and J2. A D-size VXIbus system has three sets of bus connectors called J1, J2, and J3.
BERR*	Bus error signal.
BIOS	Basic Input/Output System. BIOS functions are the fundamental level of any PC or compatible computer. BIOS functions embody the basic operations needed for successful use of the computer's hardware resources.
bus	The group of conductors that interconnect individual circuitry in a computer. Typically, a bus is the expansion vehicle to which I/O or other devices are connected. Examples of buses include the ISA bus, PCI bus, VXI bus, and VME bus.
bus error	An error that signals failed access to an address. Bus errors occur with low-level accesses to memory and usually involve hardware with bus mapping capabilities. For example, nonexistent memory, a nonexistent register, or an incorrect device access can cause a bus error.
C	
c	Celsius
CLKIO	A 10 MHz, ± 100 ppm, individually buffered (to each module slot), differential ECL system clock that is sourced from Slot 0 of a VXIbus mainframe and distributed to Slots 1 through 12 on P2. It is distributed to each slot as a single-source, single-destination signal with a matched delay of under 8 ns.
CMOS	Complementary Metal Oxide Semiconductor. A process used in making chips.
D	
DIN	Deutsches Institut für Normung. German Standards Institute.
DMA	Direct Memory Access. A method by which data is transferred between devices and internal memory without intervention of the central processing unit. DMA is the fastest method of transferring data to/from computer memory.
DRAM	Dynamic RAM (Random Access Memory). Storage that the computer must refresh at frequent intervals.

E

ECL	Emitter-Coupled Logic.
EDO	Extended Data Out. A DRAM architecture that shortens overall access latency, improving performance.
EEPROM	Electrically Erasable Programmable Read Only Memory. ROM that can be erased with an electrical signal and then reprogrammed.
embedded controller	An intelligent CPU (controller) interface plugged directly into the VXI backplane, giving it direct access to the VXIbus. The embedded controller must have all required VXI interface capabilities built in.
EMC	Electromagnetic compliance.
EMI	Electromagnetic interference.
external trigger	A voltage pulse from an external source that triggers an event.

F

fair requester	A VXIbus device that will not arbitrate for the VXIbus after releasing the bus until the fair requester device detects the bus request signal inactive. This ensures all requesting devices will be granted use of the bus.
----------------	---

G

g	1. grams 2. A measure of acceleration equal to 9.8 m/s^2
GPIB	General Purpose Interface Bus (IEEE-488)
g_{RMS}	A measure of random vibration. The root mean square (RMS) of acceleration levels in a random vibration test profile.

H

hex	Hexadecimal. The numbering system with base 16, using the digits 0 to 9 and letters A to F.
Hz	Hertz. Cycles per second.

I

IDE	Integrated Drive Electronics. Denotes the most common interface to the hard drive on PCs.
IEC	International Electrotechnical Commission. The IEC publishes internationally recognized standards. IEC 60068 contains information on environmental testing procedures and severities.

IEEE	Institute of Electrical and Electronics Engineers.
in.	Inches.
I/O	Input/output. The techniques, media, and devices used to achieve communication between machines and users.
instrument driver	A set of routines designed to control a specific instrument or family of instruments.
interrupt	A means for a device to request service from another device. A computer signal telling the CPU to suspend its current task to service a designated activity.
interrupt handler	A VMEbus functional module that detects interrupt requests generated by interrupters and responds to those requests by requesting status and identify information.
interrupt level	The relative priority at which a device can interrupt.
IRQ*	Interrupt signal.
ISA	Industry Standard Architecture. Denotes a common expansion bus used in PCs.
K	
K	Kilo. 1. The standard metric prefix for 1,000 (10^3) used with units of measure such as Volts, Hertz, and Meters. 2. The prefix for 1,024 (2^{10}). Used with B (byte) in quantifying data or computer memory.
L	
LED	Light-emitting diode.
M	
m	Meters.
M	Mega- 1. The standard metric prefix for 1 million (10^6) when used with units of measure such as Volts and Hertz. 2. The prefix for 1,048,576 (2^{20}) when used with B (byte) to quantify data or computer memory.
MANTIS	A custom ASIC that performs VXIbus arbitration and manages interrupts and triggers.
master	A functional part of a VME/VXIbus device that initiates data transfers on the backplane. A transfer can be either a read or a write.
MBLT	Eight-byte block transfers in which both the Address bus and the Data bus are used to transfer data.

MITE	A custom ASIC. A dual-channel DMA controller that incorporates the Synchronous MXI and VME64 protocols to achieve high-performance block transfer rates.
MODID	Module ID lines. Used in VXI to geographically locate boards and to dynamically configure boards.
MTBF	Mean Time Between Failures.

N

NI-488.2 or NI-488.2M	National Instruments software for controlling GPIB instruments.
NI-VISA	National Instruments implementation of the VISA standard. An interface-independent software that provides a unified programming interface for VXI, GPIB, and serial instruments.
NI-VXI	National Instruments bus interface software for VME/VXIbus systems.
Non-Slot 0 device	A device configured for installation in any slot in a VXIbus mainframe other than Slot 0. Installing this type of device into Slot 0 can damage the device, the VXIbus backplane, or both.

P

PCI	Peripheral Component Interconnect. The PCI bus is a high-performance 32-bit or 64-bit bus with multiplexed address and data lines.
PCMCIA	Personal Computer Memory Card International Association.
POSC	Power-On Self-Configuration. A process by which the MITE chip programs its own registers from EEPROMs at power up.

R

Resource Manager	A message-based Commander located at Logical Address 0 that provides configuration management services such as address map configuration, Commander and Servant mappings, and self-test and diagnostic management.
RMS	Root mean squared. <i>See</i> g_{RMS} .

S

s	Seconds.
SCSI	Small Computer System Interface (bus).
SICL	Standard Instrument Control Library. A device-independent instrument I/O Applications Programming Interface (API) developed by Agilent Technologies.
simm	Single In-line Memory Module.

slave	A functional part of a VME/VXIbus device that detects data transfer cycles initiated by a VMEbus master and responds to the transfers when the address specifies one of the device's registers.
Slot 0 device	A device configured for installation in Slot 0 of a VXIbus mainframe. This device is unique in the VXIbus system in that it performs the VXI/VMEbus System Controller functions, including clock sourcing and arbitration for data transfers across the backplane. Installing this type of device into any other slot can damage the device, the VXIbus backplane, or both.
SMB	Sub Miniature Type B connector that features a snap coupling for fast connection.
SYSFAIL	A VMEbus signal used by a device to indicate an internal failure. A failed device asserts this line. In VXI, a device that fails also clears its PASSEd bit in its Status register.

T

trigger	Either TTL or ECL lines used for intermodule communication.
TTL	Transistor-Transistor Logic.

V

v	Volts.
VGA	Video Graphics Array. The minimum video display standard for all PCs.
VISA	Virtual Instrument Software Architecture. This is the general name given to VISA and its associated architecture.
VME	Versa Module Eurocard or IEEE 1014.
VXIbus	VMEbus Extensions for Instrumentation.

A

- ACC LED, 33
- adding additional RAM, 54
- advanced graphics port (AGP), 14
- Agilent documentation set, using, 10
- Agilent Technologies web site, 25, 67
- Agilent VEE, 17
- AGP graphics controller, features, 35
- application development environments (ADEs), 16
- application programming interface (API), 15
- application software, 17
- applications, developing, 25
- AT-style keyboards, 22
- automatic system controller slot detection, 21

B

- BIOS code, features, 36
- BIOS setup program, 24
- block move operations, 29

C

- Card Bus expansion, 35
- CDs
 - E9850A, 11
 - NI-488.2 for Windows, 11
- checking your shipment, 19
- chip set and SDRAM, features, 34
- cleaning instructions, 52
- CLK10 routing and termination, setting, 48
- CMOS contents, clearing, 46
- CMOS corrupted, fixes, 64
- COM1 and COM2 connectors, 82
- configuration
 - CLK10 routing and termination, setting, 48
 - CPU bus factor, setting, 47
 - CPU bus speed, setting, 46
 - Ethernet serial EEPROM settings, 47
 - flash protection, setting, 47
 - MITE EEPROM, setting, 44
 - power-on self-configuration, 43
 - SCSI termination, setting, 45
 - system CMOS, setting, 46
 - system controller operation, setting, 43
 - trigger input termination, setting, 48

- voltage monitor, setting, 48
- WatchDOG, setting, 48
- configuration utilities, using, 25
- configuration, E9850A, 39
- connector descriptions
 - COM1 and COM2 connectors, 82
 - Ethernet connector, 87
 - GPIO (IEEE-488.2) connector, 88
 - keyboard/mouse connectors, 79
 - P1 and P2 connectors, 91
 - parallel port connector, 83
 - SCSI connector, 85
 - SMB connectors, 90
 - speaker connection, 81
 - SVGA connector, 78
 - universal serial bus (USB) connector, 80
- CPU bus factor, setting, 47
- CPU bus speed, setting, 46
- Current Requirements, 60
- customer support, 12, 67

D

- debugging
 - using NI Spy, 29
 - using VISAIC, 29
- default settings
 - hardware default settings, 39
 - T&M Explorer, 41
- developing your application, 25
- device interaction, 27
- DMA transfers, 37
- documentation
 - related documentation, 12
 - using Agilent documentation set, 10
 - using National Instruments documentation set, 11
- documentation history, 6
- driver software, 15

E

- E9850A
 - CD, 11
 - configuration, 39
 - Configuration Form, 24, 68
 - description, 31
 - exchanging, 50

- installing, 21
- serial number, 65
- servicing, 49
- specifications, 59

EEPROM corrupted, fixes, 44

electrostatic discharge (ESD), 21

Ethernet

- 100 LED, 33
- connector, 87
- features, 35
- serial EEPROM, settings, 47

exchanging the E9850A, 50

external VXI CLK10 synchronization, 37

F

FAILED LED, 33

FAILSAFE defaults, 24

features

- AGP graphics controller, 35
- BIOS code, 36
- Card Bus expansion, 35
- chip set and SDRAM, 34
- DMA transfers, 37
- Ethernet, 35
- external VXI CLK10 synchronization, 37
- fused power protection, 36
- IEEE-488.2, 35
- MXI addressing, 36
- PCI or ISA card expansion, 35
- PIIX4, 35
- processor, 34
- programmable reset circuitry, 36
- real-time clock, 36
- SCSI-3, 35
- super IO, 35
- VXI interrupts, 37
- VXI slot 0 functionality, 36
- VXI trigger lines, 37
- VXI voltage monitor circuitry, 36
- WatchDOG counter/timer, 36

flash protection, setting, 47

front panel features

- LED indicators, 33
- SVGA connector, 34

fused power protection, 36

G

glossary, 93

GPIO (IEEE-488.2) connector, 88

H

hard drive image, reloading, 24

hard drive, replacing, 54

hardware features, 13

I

I/O expansion cards, installing, 55

IDE LED, 33

IEEE-488.2, features, 35

installing I/O expansion cards, 55

installing the E9850A, 21

instrument sessions, 26

K

keyboard/mouse connectors, 79

L

LabVIEW, 17

LabWindows/CVI, 17

latest information files, 25

LED indicators, 33

LEDs

- ACC LED, 33
- Board Access, 33
- Ethernet 100, 33
- FAILED LED, 33
- IDE LED, 33
- ONLINE LED, 33
- PWR LED, 33
- SCSI LED, 33
- SYSF LED, 33
- VXIbus Interface Status, 33

M

main power fuse, changing, 52

MANTIS custom ASIC, 36

manual conventions, 9

mini-DIN connector, 22

MITE ASIC, description, 36

MITE EEPROM, setting, 44

MXI addressing, features, 36

N

NI Spy, 16

NI-488.2 CD, 11

O

online (.pdf) manuals, 11
ONLINE LED, 33
operating system, re-installing, 64
OPTIMAL defaults, 24

P

P1 and P2 connectors, 91
parallel port connector, 83
PCI or ISA card expansion, 35
peripheral component interface (PCI) bus, 14
peripherals support information, 24
PIIX4, features, 35
porting considerations, 71
 default SICL interface name changes, 71
 resource manager differences, 71
 SICL/VISA differences, 73
power-on self-configuration (POSC) circuit, 44
power-on self-configuration, setting, 43
processor, features, 34
programmable reset circuitry, features, 36
programming
 using SICL, 27
 using VISA, 28
programming interfaces, 27
PWR LED, 33

Q

questions, 63

R

RAM, adding additional, 54
real-time clock, features, 36
register access operations, 29
reloading the hard drive image, 24
removing the cover, 53
repair/installation
 adding additional RAM, 54
 changing main power fuse, 52
 cleaning instructions, 52
 installing I/O expansion cards, 55
 removing the cover, 53
 replacing the hard drive, 54
replaceable parts list, 49
replacing the hard drive, 54
Resman, using, 26, 64
Resource Manager, 16, 26, 66
restricted rights statement, 5

S

safety symbols, 6
SCSI connector, 85
SCSI LED, 33
SCSI termination, setting, 45
SCSI-3, features, 35
serial number, E9850A, 65
servicing the E9850A, 49
shipment items, 19
shipment, checking, 19
SICL, 15, 27
SMB connectors, 90
SODIMMs, recommended, 54
software architecture, 14
software, driver, 15
speaker connection, 81
specifications
 current requirements, 60
 environmental, 60
 general, 59
 general VXI specifications, 59
 physical, 59
 VMEbus capability codes, 61
specifications, E9850A, 59
Super IO, features, 35
support, customer, 67
SVGA connector, 34, 78
SYSF LED, 33
system CMOS, setting, 46
system controller operation, setting, 43

T

T&M Explorer, 16
 default settings, 41
 overview, 16
 using, 27
telephone numbers, Agilent Technologies, 67
trademark information, 8
trigger input termination, setting, 48
troubleshooting techniques, 51

U

Ultra DMA 33 IDE interface, 35
universal serial bus (USB) connector, 80
using configuration utilities, 25

V

- VISA, 15
- VME devices, handling, 65
- VME support, 28
- VMEbus capability codes, 61
- voltage monitor, setting, 48
- VXI interrupts, features, 37
- VXI slot 0 functionality, 36
- VXI trigger lines, features, 37
- VXI voltage monitor circuitry, features, 36
- VXIbus data transfer bus arbiter, 43

W

- WARNINGS, 6
- warranty statement, 5
- WatchDOG
 - features, 36
 - setting, 48
- web site
 - Agilent Technologies, 11, 25, 67
 - National Instruments, 12